

# ENERGY RELAXATION IN THE QUANTUM HALL REGIME

C. Altimiras, H. le Sueur, U. Gennser, A. Cavanna, D. Mailly, F. Pierre

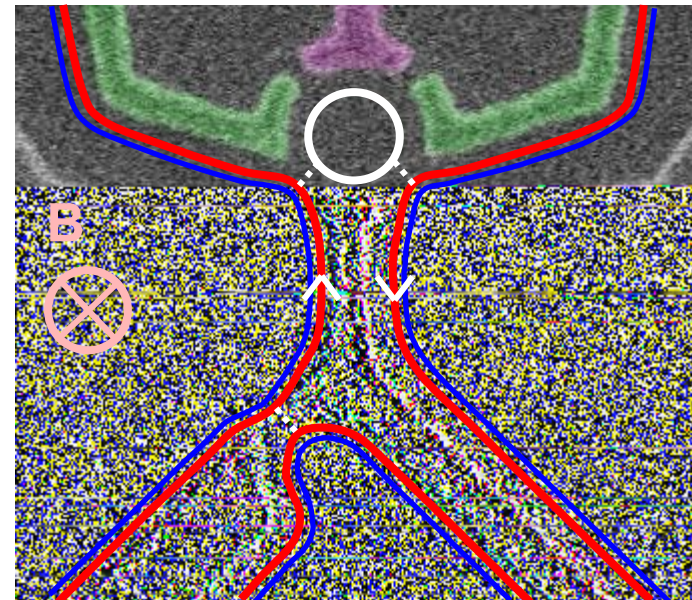

# The Quantum Hall Regime

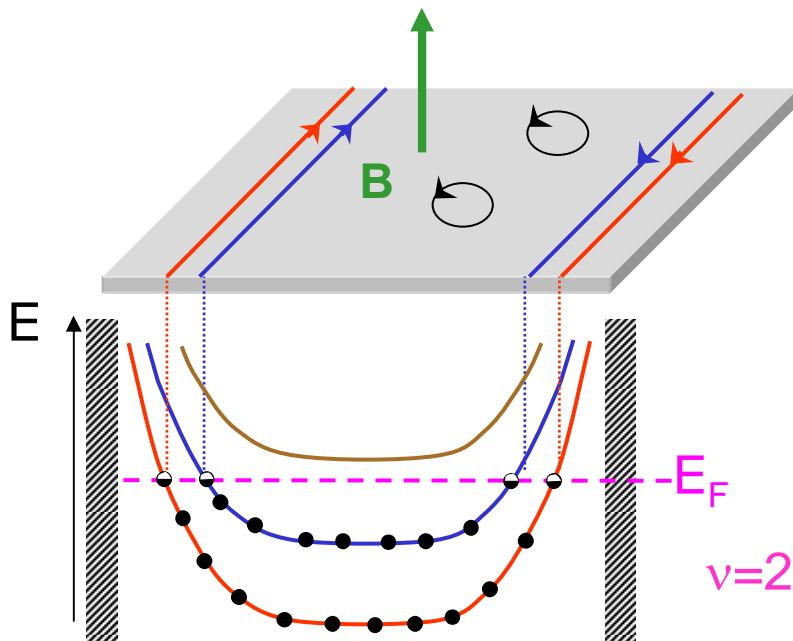
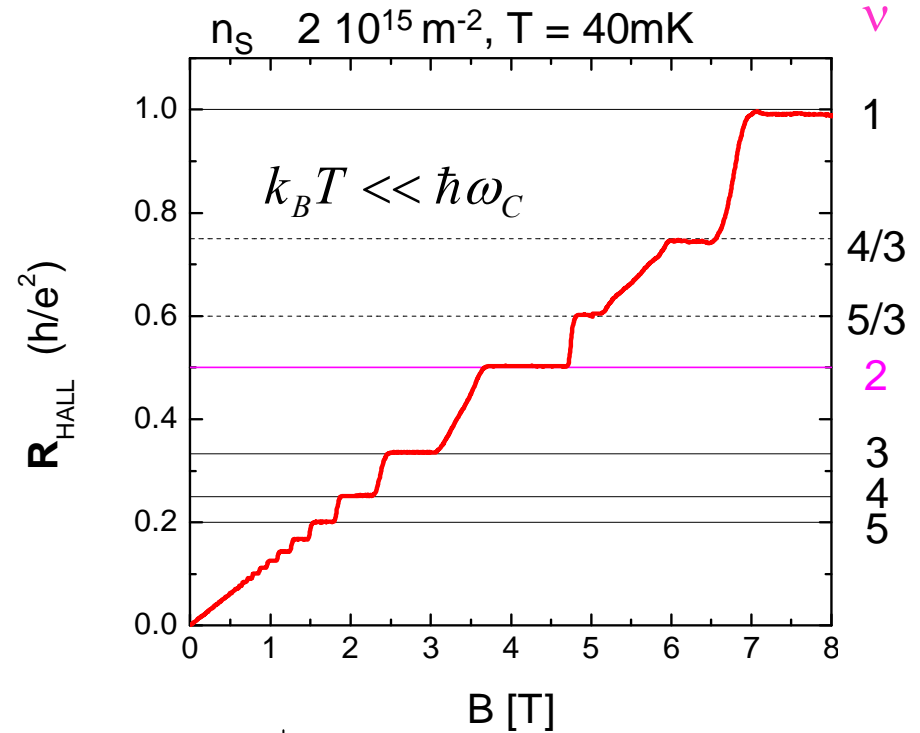
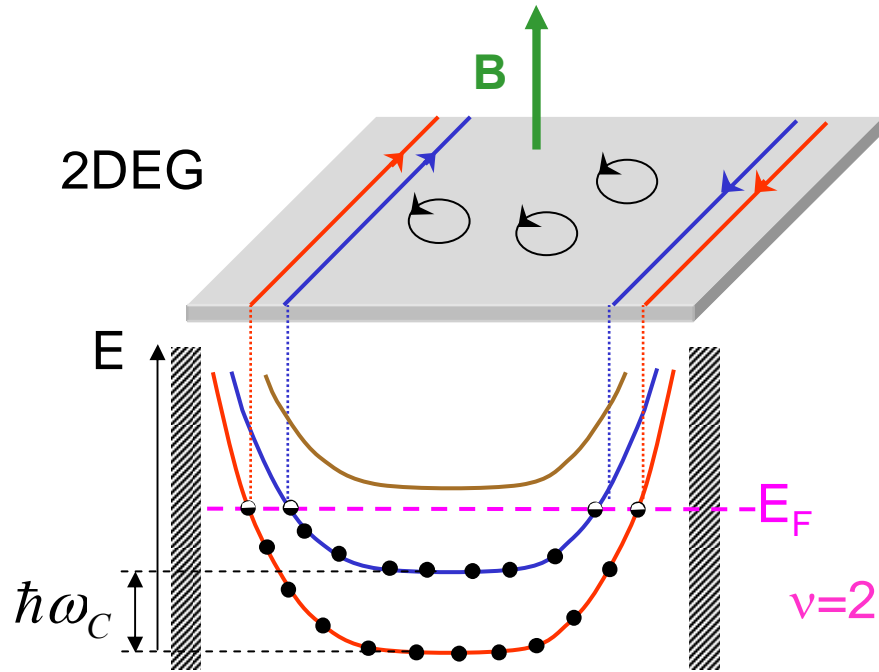

Landau levels:  
(spinless)

$$E_n(k) \approx (n+1/2)\hbar\frac{eB}{m} + V_{conf}(y_k = -k\frac{\hbar}{eB})$$

$$r_C = v_F / \omega_C$$

$$r_C \ll l_e$$

Non interacting electrons  
1D chiral Fermions

# Unexpected behavior of electronic excitations

EXPERIMENTAL OBSERVATIONS in MZI (at  $\nu=2$ )

- **Unexpected energy dependent visibility**

Ji *et al.* (Nature 2003)    Neder *et al.* (PRL 2006)  
 Bieri *et al.* (PRB 2009)    Roulleau *et al.* (PRL 2008)

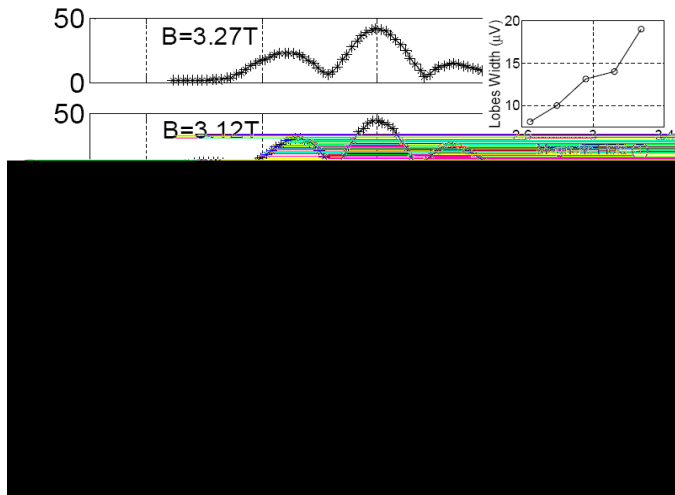

- **Non gaussian noise**

Neder *et al.* (Nature Phys. 2007)

- **Low coherence length**

$$L_\phi \sim 20\mu\text{m}/(T/20\text{mK})$$

Litvin *et al.* (PRB 2007)  
 Roulleau *et al.* (PRL 2008)

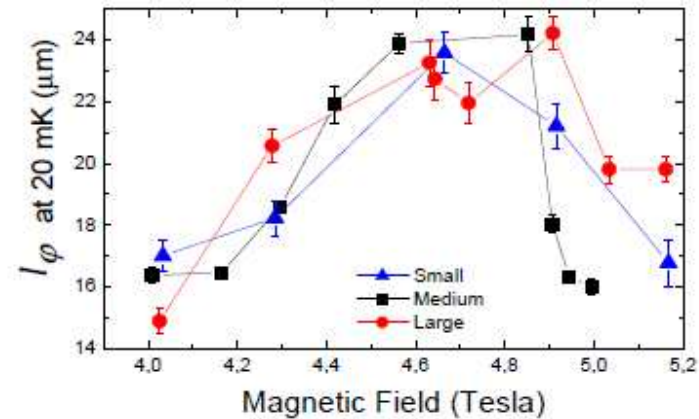

- **Noise induced dephasing**

Noise in 1 EC  $\Rightarrow$  **dephasing** in other EC

Roulleau *et al.* (PRL 2008)

ELECTRONS  $\rightarrow$  COULOMB INTERACTION

Alternative descriptions: **bosonic modes** (collective excitations)  
**additional electronic excitations** (charge density oscillations)

**A NEW APPROACH:**

# **Probing Energy Transport**

In The Quantum Hall Regime

***Spectroscopy of non-equilibrium electrons:***

*Altimiras et al. (Nature phys. 2010)*

## **MAIN INGREDIENTS**

1) **creation** of a **non-equilibrium** distribution  $f(E)$

2) **propagation** => relaxation over different lengths

3) **measurement** of  $f(E)$

# Tunable non equilibrium situation

Using a quantum point contact

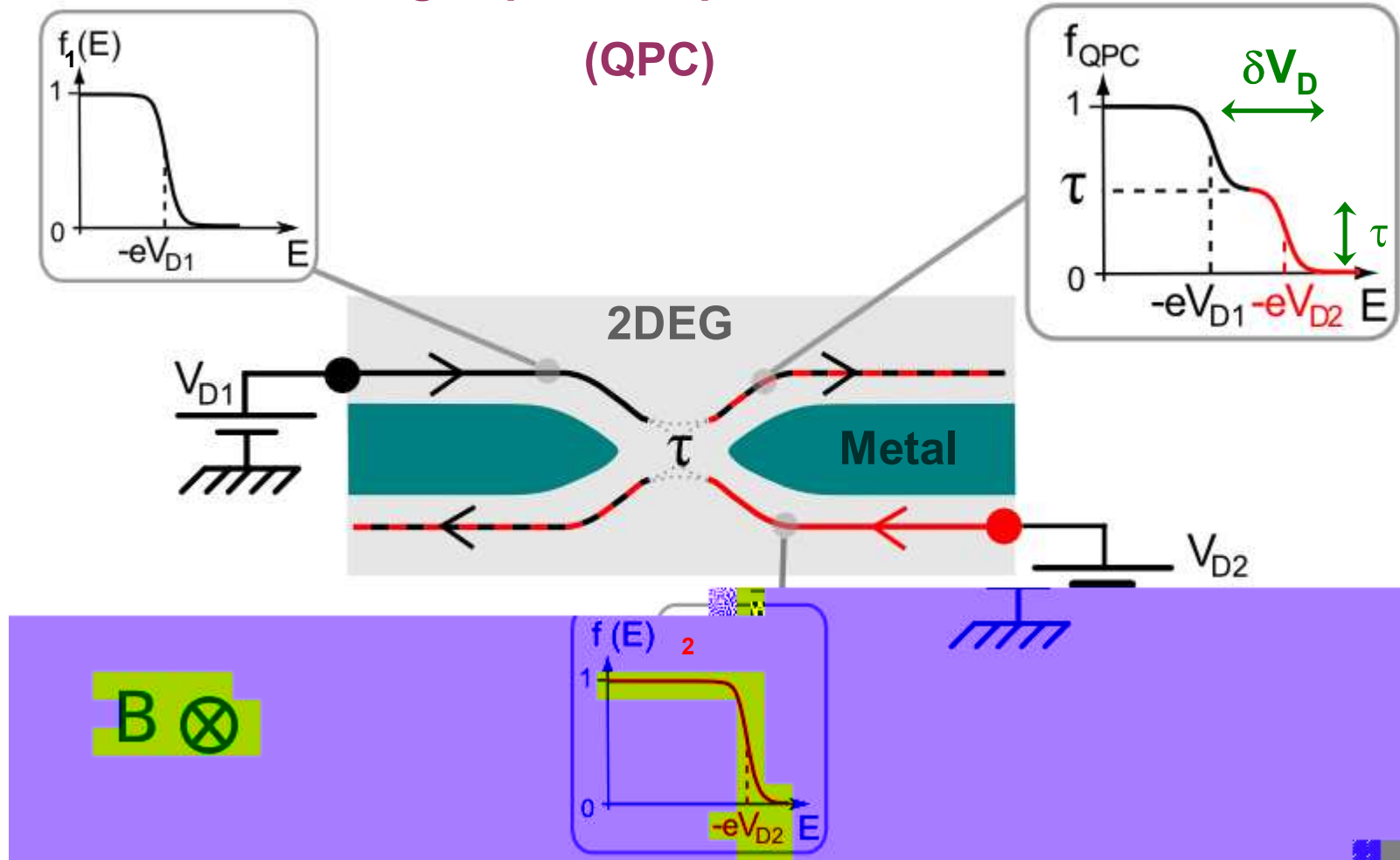

For free 1D chiral fermions :  $f_{QPC}(E) = \tau \cdot f_2 + (1 - \tau) \cdot f_1$

# Measuring $f(E)$

With the single level of a quantum dot (QD)

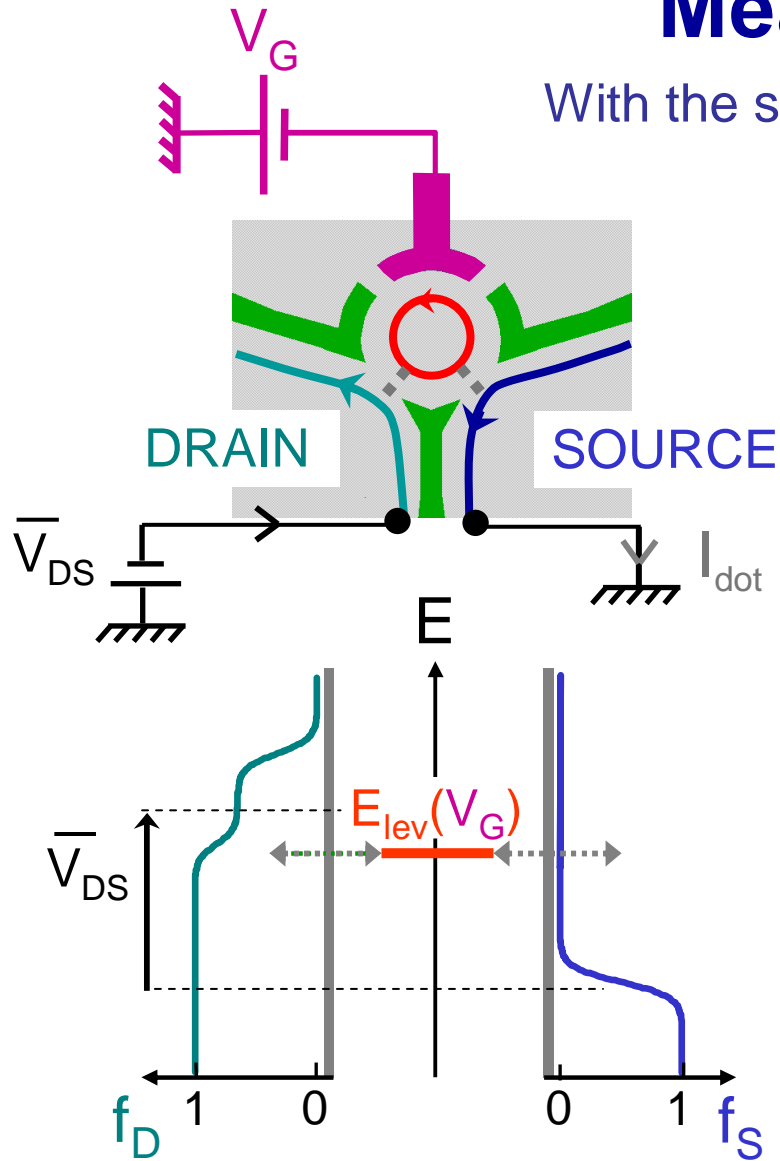

Sequential tunneling

- $I_{dot} \propto (f_S(E_{lev}) - f_D(E_{lev}))$
- $E_{lev}(V_G) = E_0 - e\eta_G V_G$

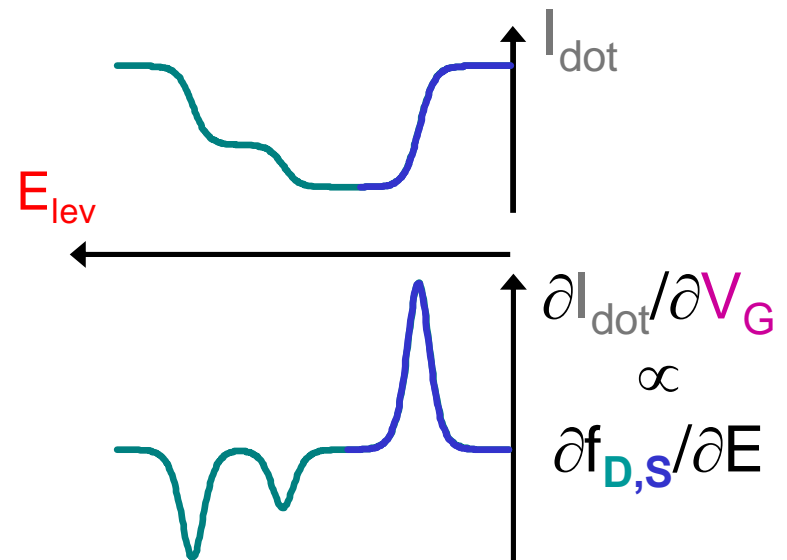

Quantum dot  $\longleftrightarrow$  Energy Filter  
(for single electrons)

# Experimental Implementation

SHORT PATH (0.8 $\mu\text{m}$ )

$B=4.25\text{T}$



$n_s = 2 \times 10^{15}\text{m}^{-2}$

$\nu=2$

$T \sim 30\text{mK}$

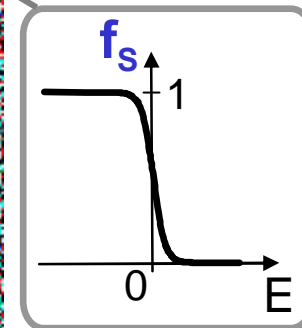
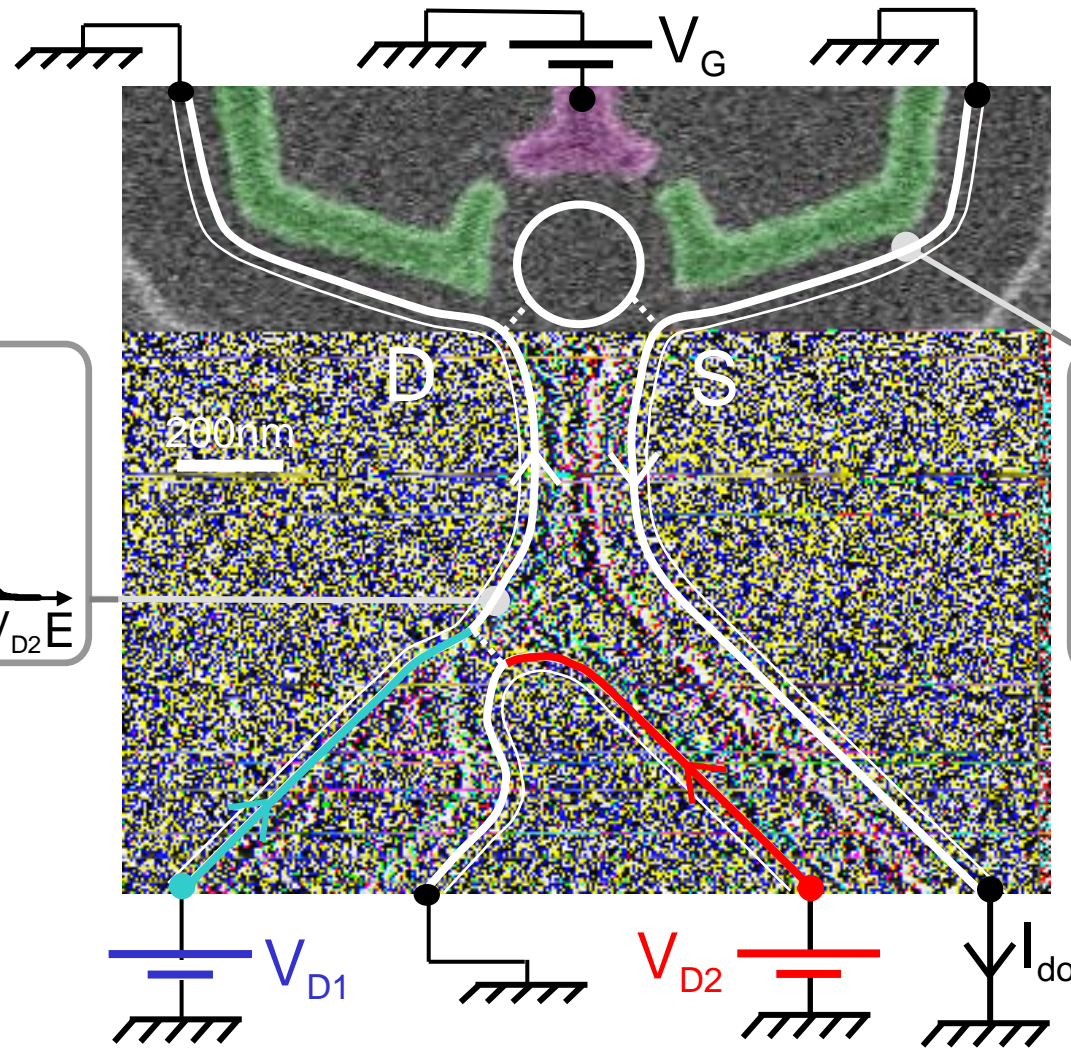
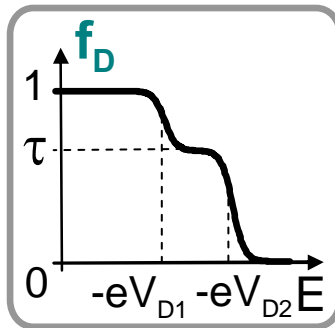

# Raw Data In Non-equ. Situation

SHORT PATH (0.8 $\mu\text{m}$ )

T~30mK

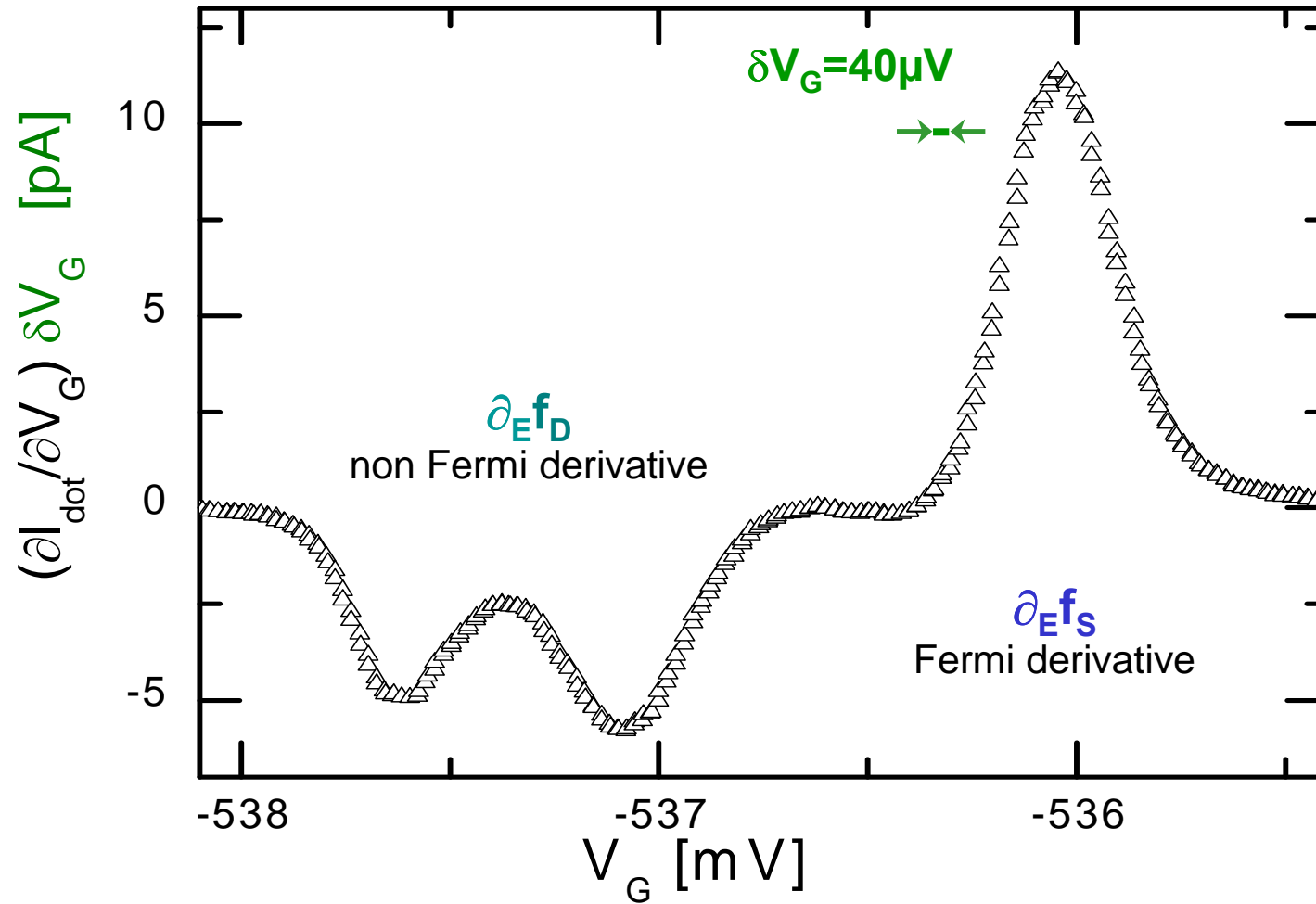

Non-Fermi  $f(E)$  (double step) on the drain side

# Tuning $f(E)$ Out-of-equilibrium

WITH QPC BIAS

SHORT PATH (0.8 $\mu\text{m}$ )

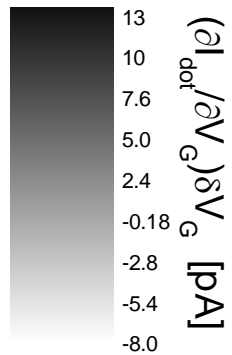

several  $\delta V_D$   
 $\tau=0.5$

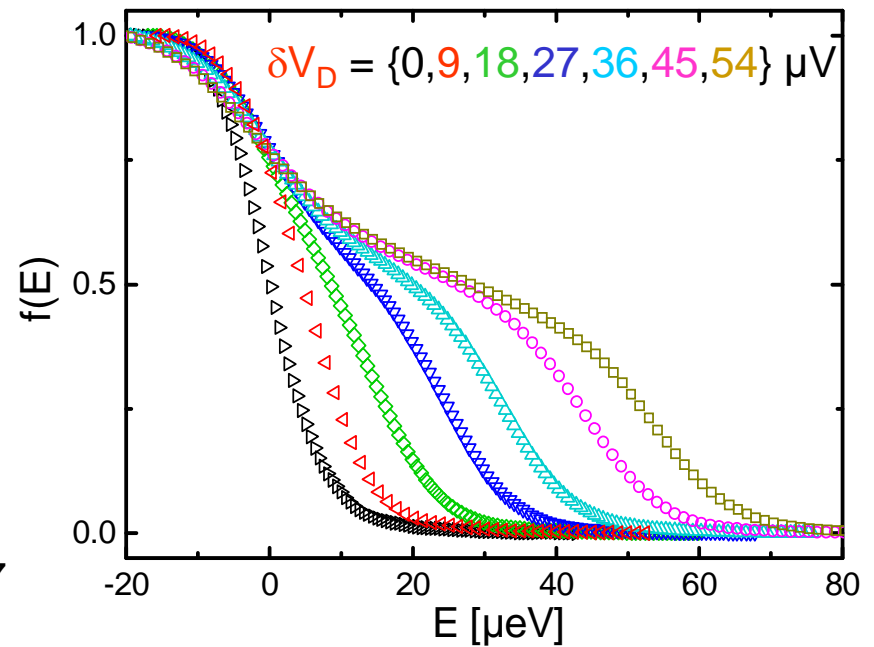
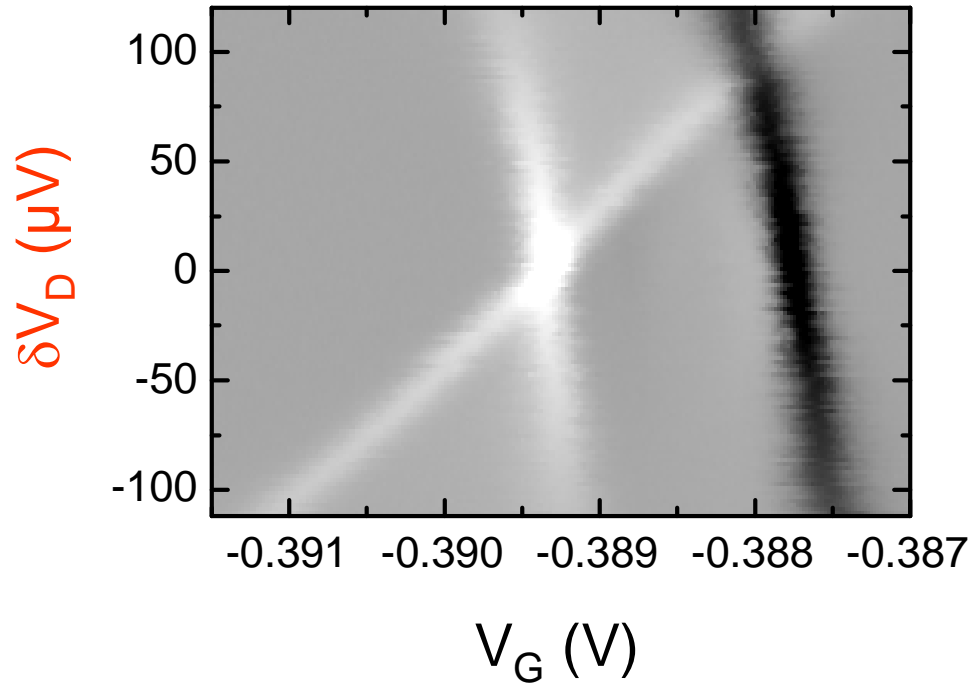
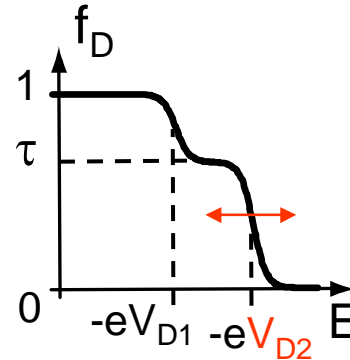

# Tuning $f(E)$ Out-of-equilibrium

WITH QPC TRANSMISSION

SHORT PATH (0.8 $\mu\text{m}$ )

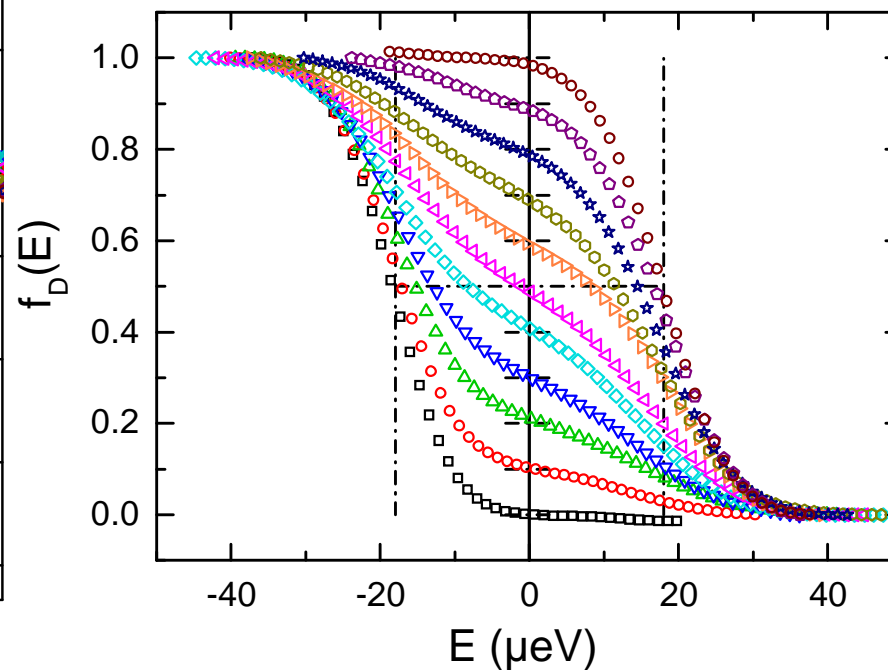
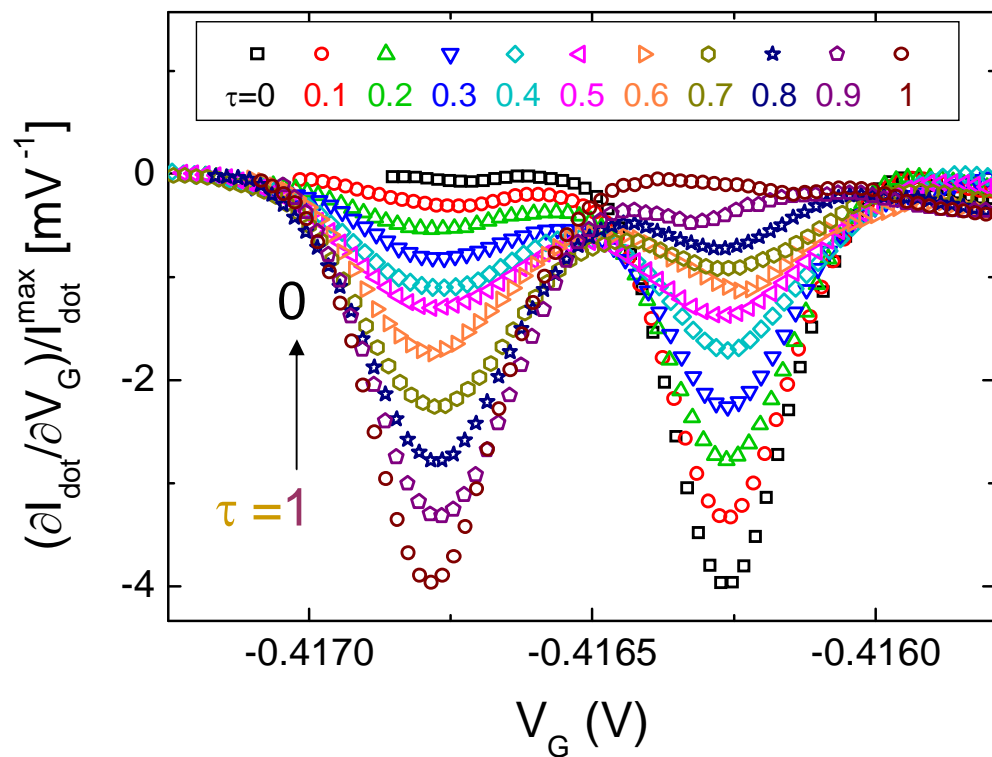
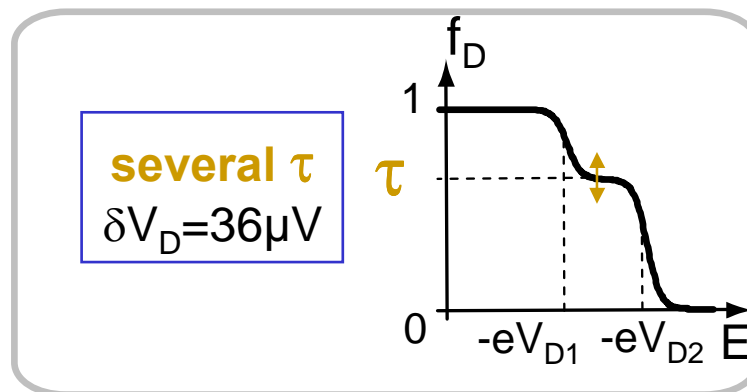

# Energy within electronic excitations

extracted from  $f(E)$

$$\frac{E_{qp}}{v_F} \equiv \int_{-\infty}^{E_F} |E - E_F| (1 - f(E)) dE + \int_{E_F}^{\infty} |E - E_F| f(E) dE$$

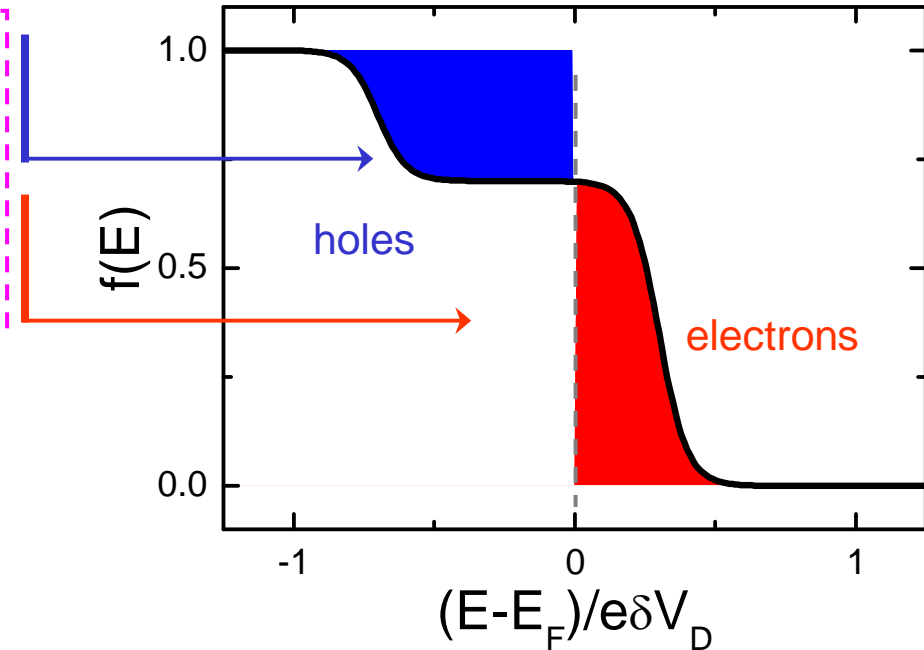

$$T_{qp} \equiv \sqrt{\frac{E_{qp}}{v_F} \frac{6}{\pi^2 k_B^2}}$$

$$T_{excess} = \sqrt{T_{qp}^2 - T_{qp \text{ equilibrium}}^2}$$

$f(E) = \text{double step}$  At the QPC output:

$$\left\{ \begin{array}{l} \frac{E_{qp}^{QPC}}{v_F} = \frac{(\pi k_B T)^2}{6} + \frac{(e\delta V_D)^2}{2} \tau(1-\tau) \end{array} \right.$$

$$T_{qp}^{QPC} = \sqrt{T^2 + \frac{3e^2 \delta V_D^2}{\pi^2 k_B^2} \tau(1-\tau)}$$

$$T_{excess}^{QPC} = \sqrt{\frac{3e^2 \delta V_D^2}{\pi^2 k_B^2} \tau(1-\tau)}$$

# Checkpoint Short path (0.8 $\mu\text{m}$ )

Altimiras *et al.* (Nature phys. 2010)

## Excess temperature of electronic system

$\tau=0.5$   
 $\delta V_D$

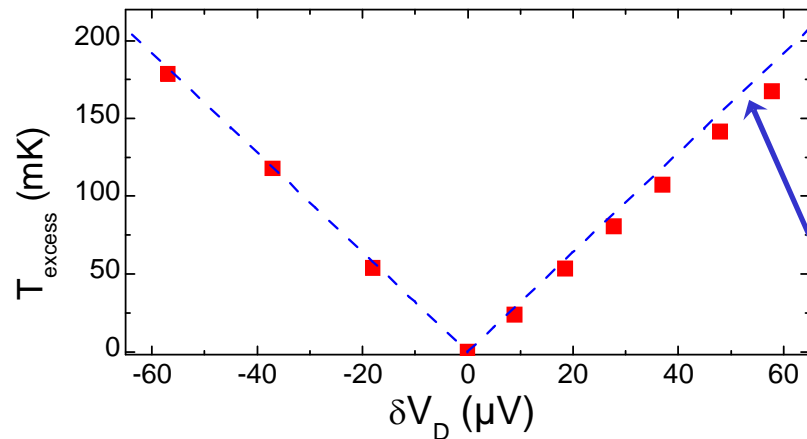

$$T_{\text{excess}} = \sqrt{T_{qp}^2 - T_{qp}^2 [\delta V_D = 0]}$$

$\tau$   
 $\delta V_D=36\mu\text{V}$

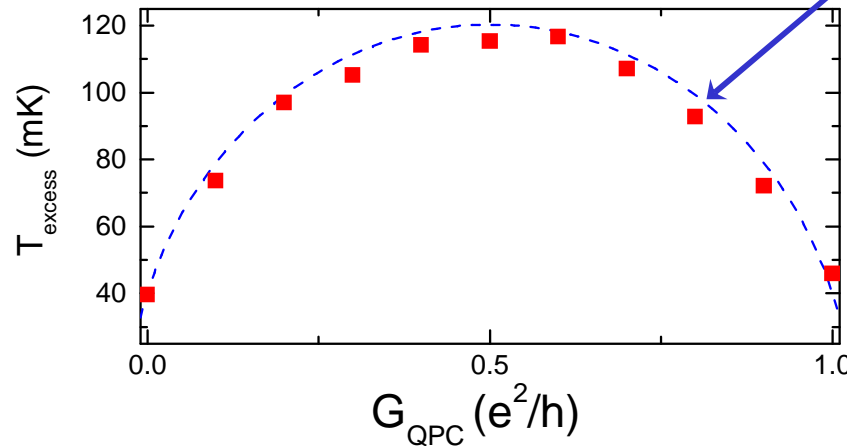

$$T_{\text{excess}}^{\text{QPC}} = \sqrt{\frac{3e^2 \delta V_D^2}{\pi^2 k_B^2} \tau(1-\tau)}$$

QPC is a partitioner for 1DCFs  
 QD is a precise energy filter  
 Free 1DCF behavior on short distance

# Varying the propagation length

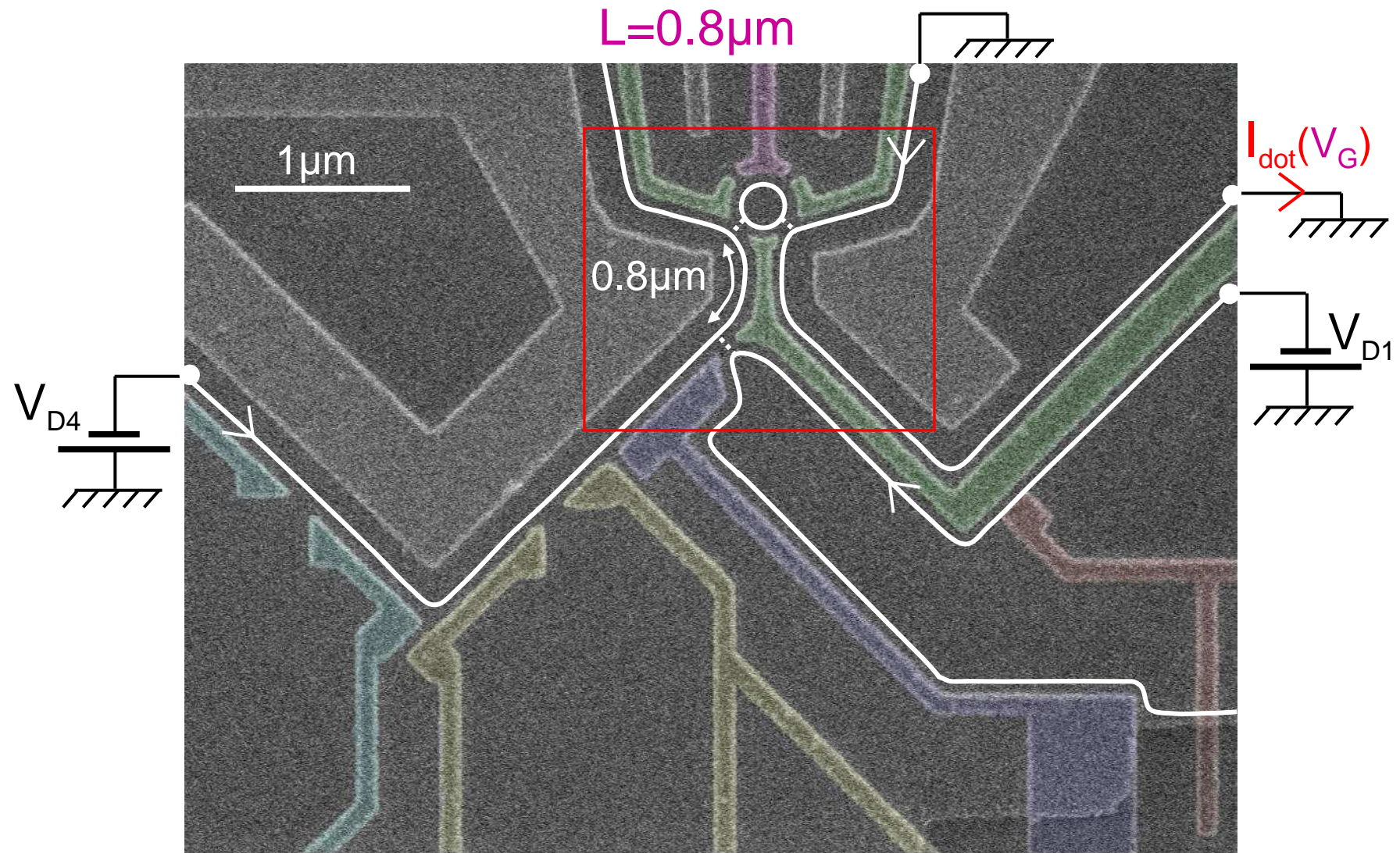

Inner EC not shown

# Varying the propagation length

$L=2.2 \text{ \& } 4 \text{ \mu m}$

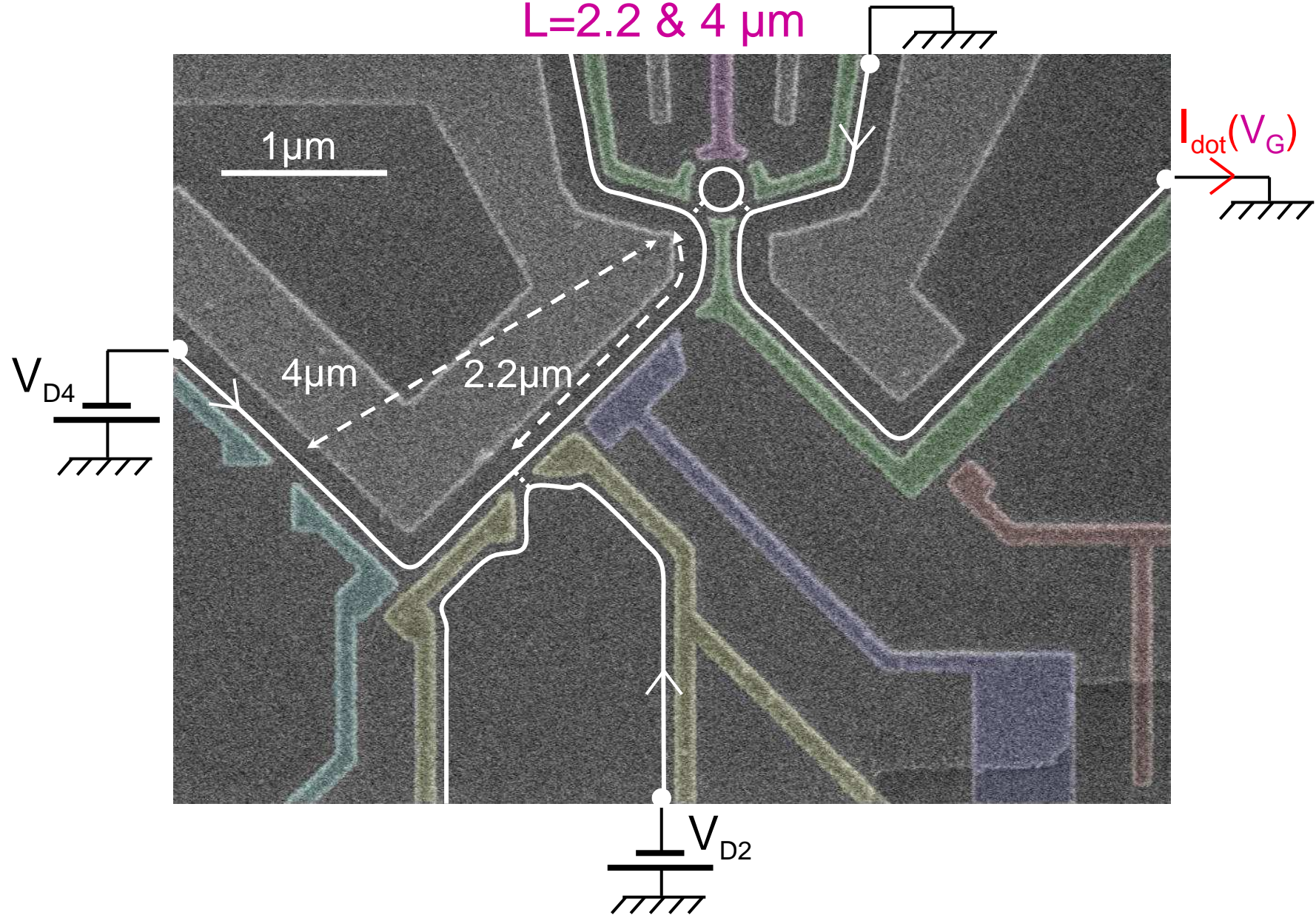

# Varying the propagation length

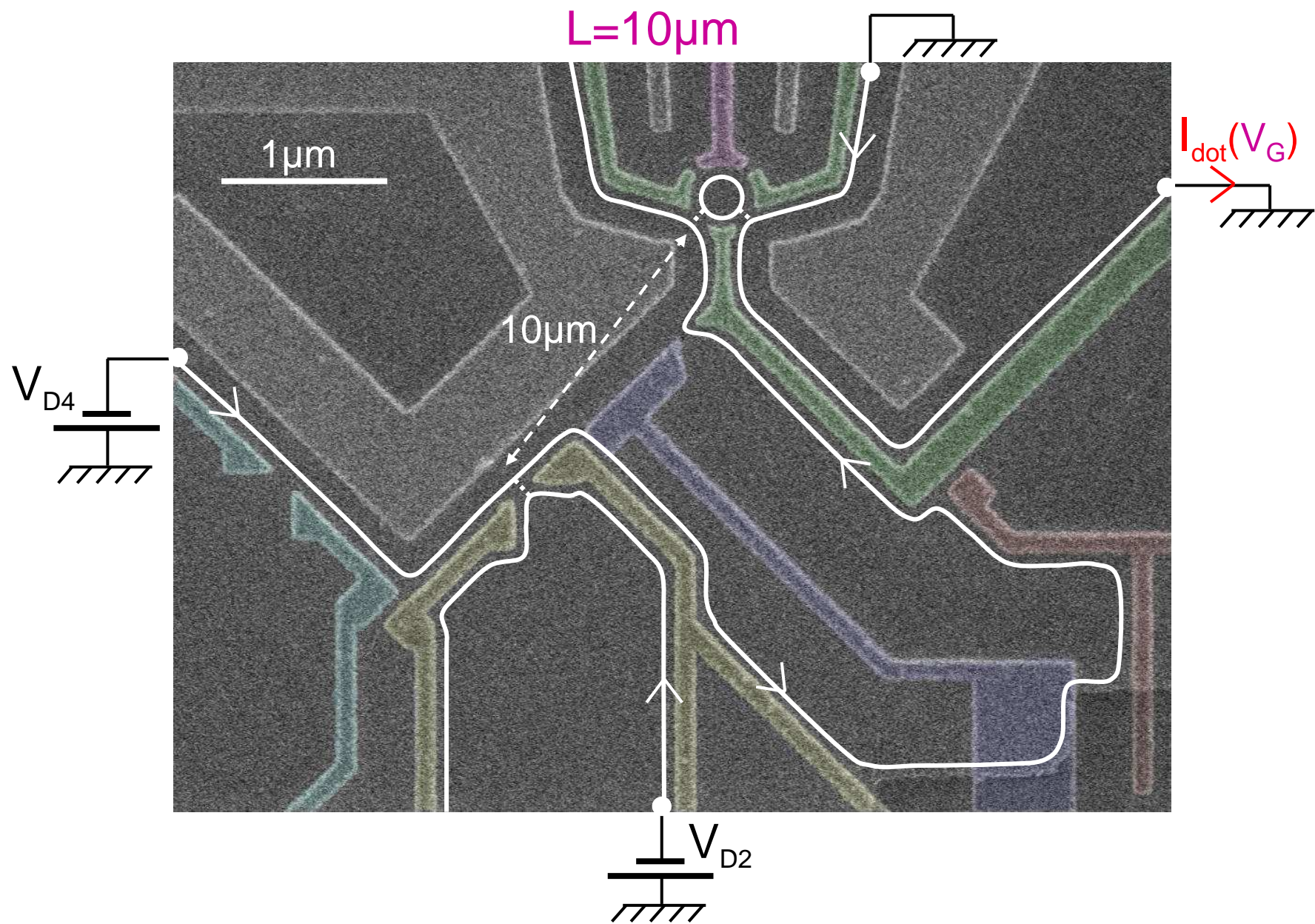

# Varying the propagation length

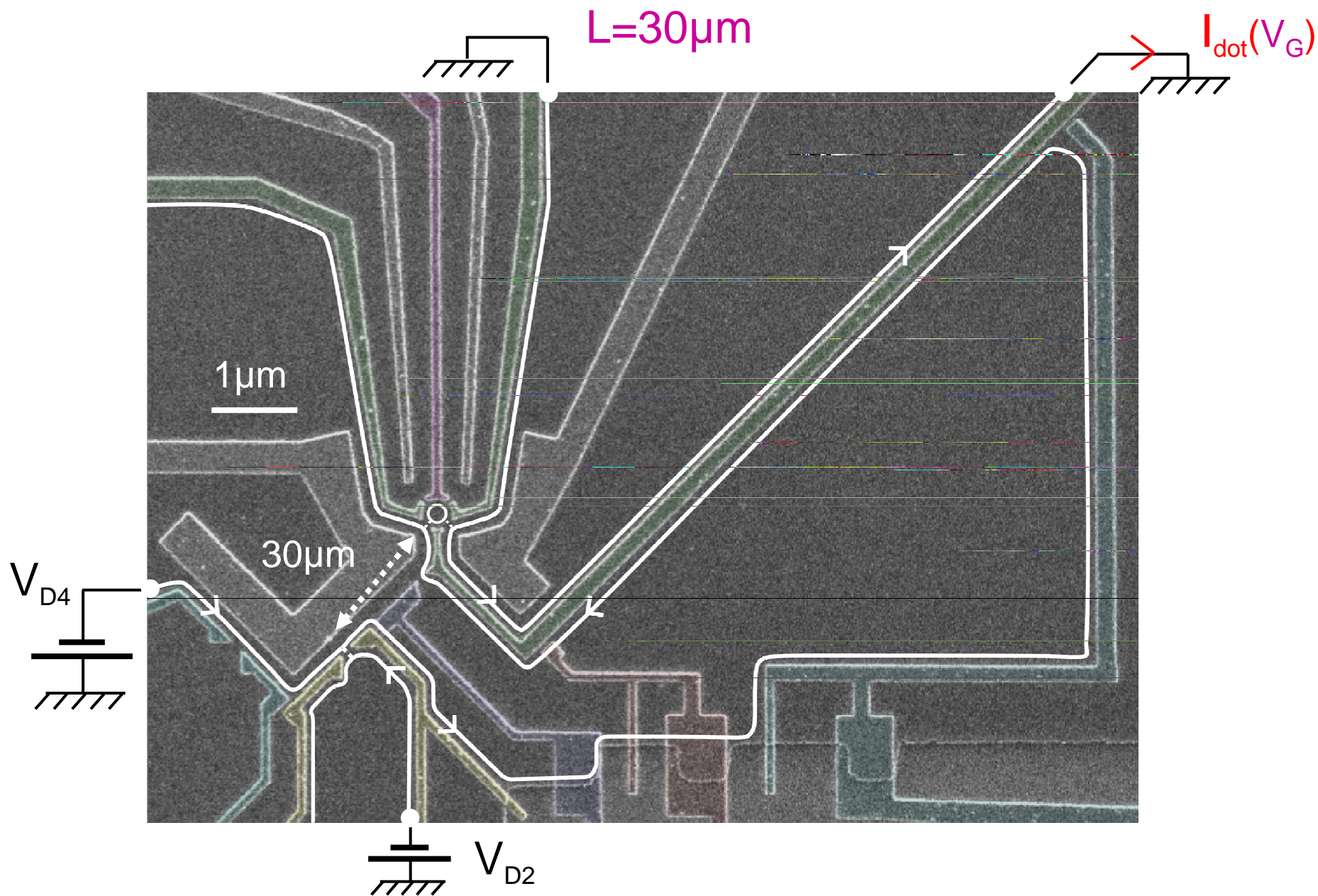

# Energy distribution in outer EC

$$\delta V_D = 36 \mu\text{V}, \tau \sim 0.5$$

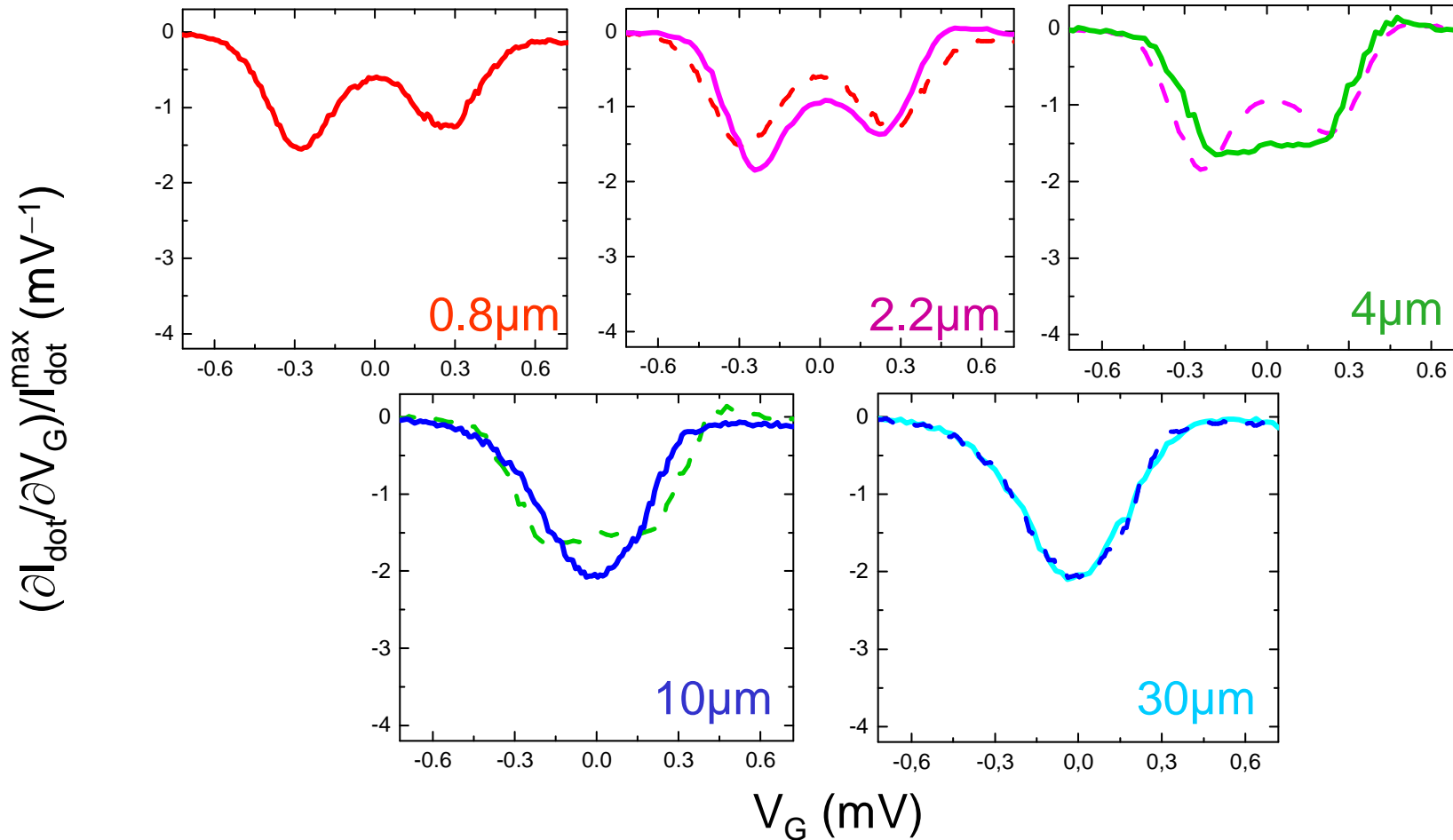

- $f(E)$  relaxation! ●  $L_{\text{inelastic}} \sim 3 \mu\text{m}$  ( $\delta V_D = 36 \mu\text{V}$ ,  $\tau \sim 0.5$ )
- $f(E)$  **saturates** to a Fermi function after  $10 \mu\text{m}$

# Outer EC's electronic temperature

$L = \{ 0.8, 2.2, 4, 10, 30 \} \mu\text{m}$ ,  $\tau = 0.5$ ,  $T = 30\text{mK}$

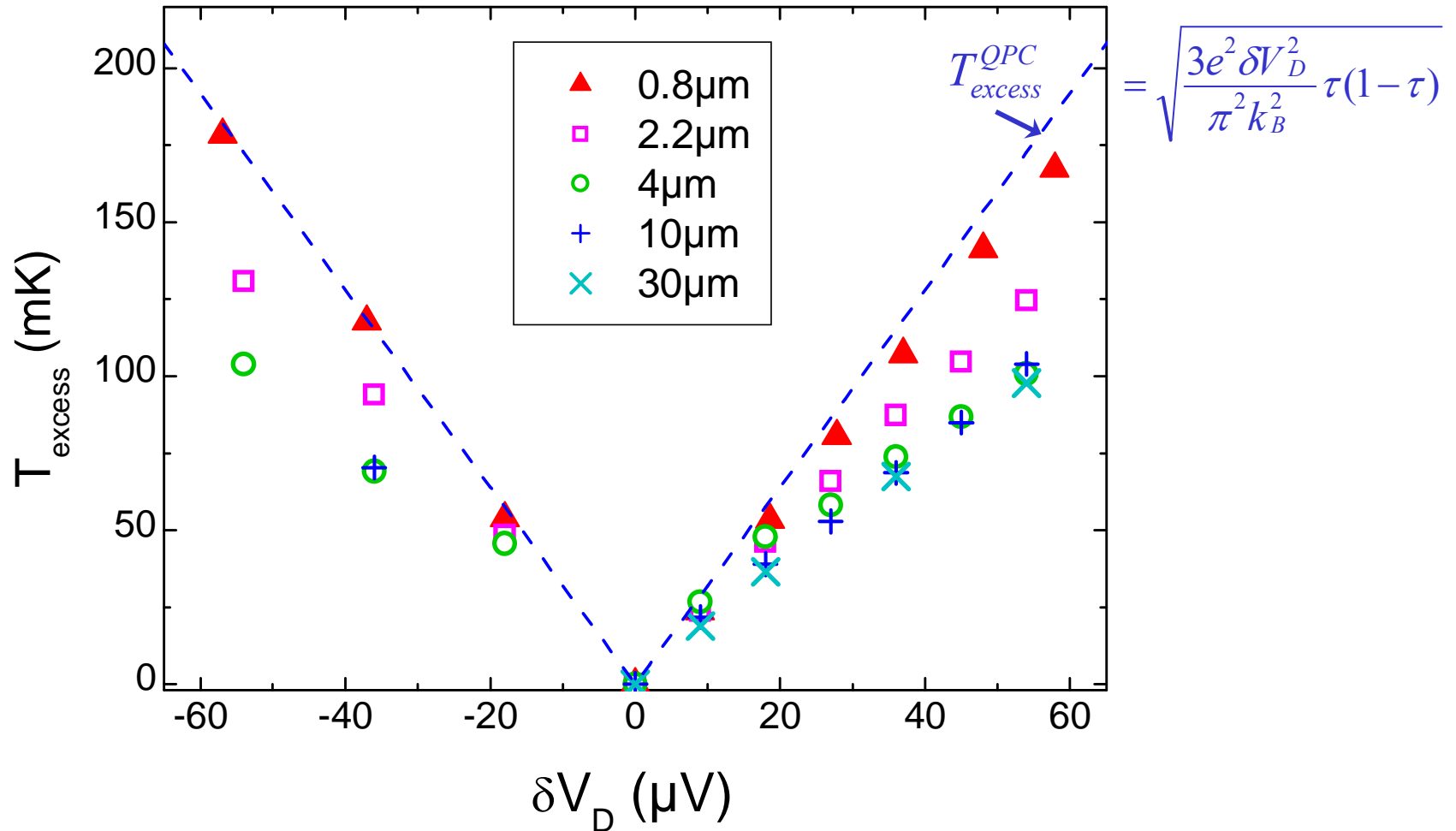

Energy lost toward a **co-propagating** mode:  
Inner EC? Additional modes (charge density oscillations)?

# Energy exchanges between ECs?

Energy injected in Inner EC

$f(E)$  meas. in outer EC

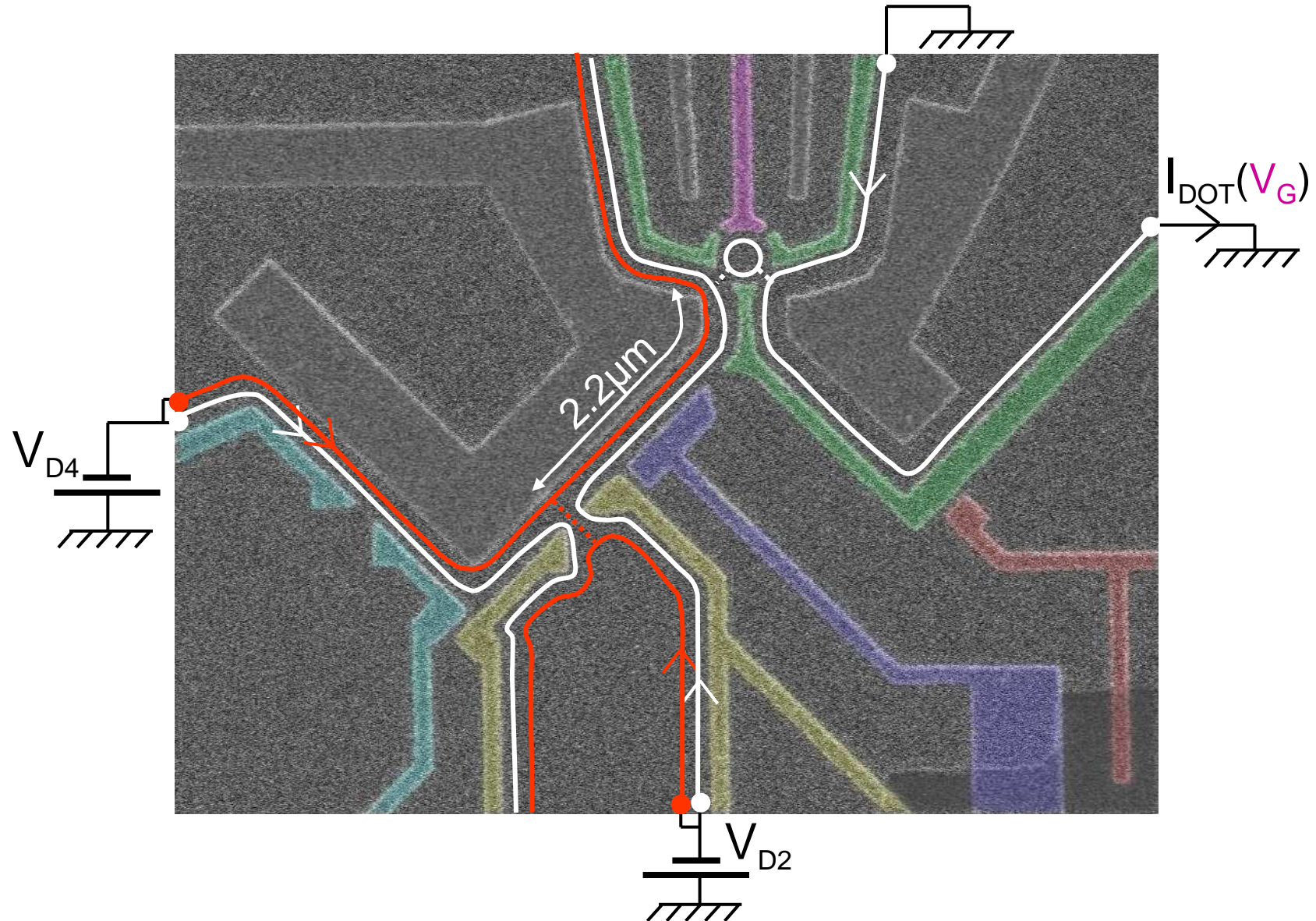

# Energy exchanges between ECs?

Energy injected in Inner EC

$f(E)$  meas. in outer EC

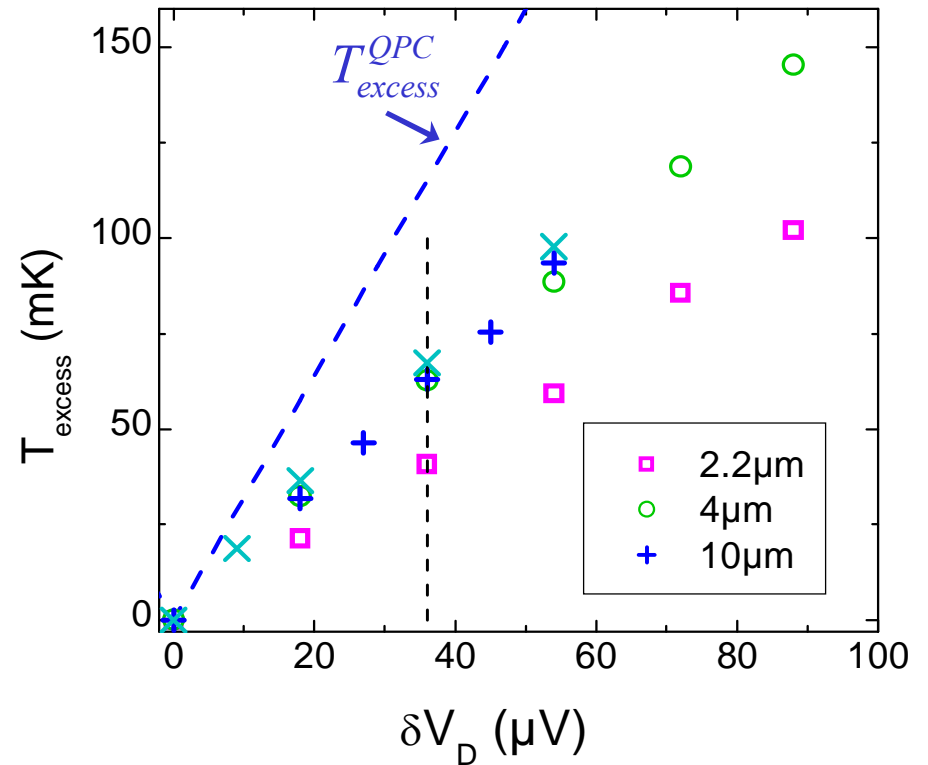
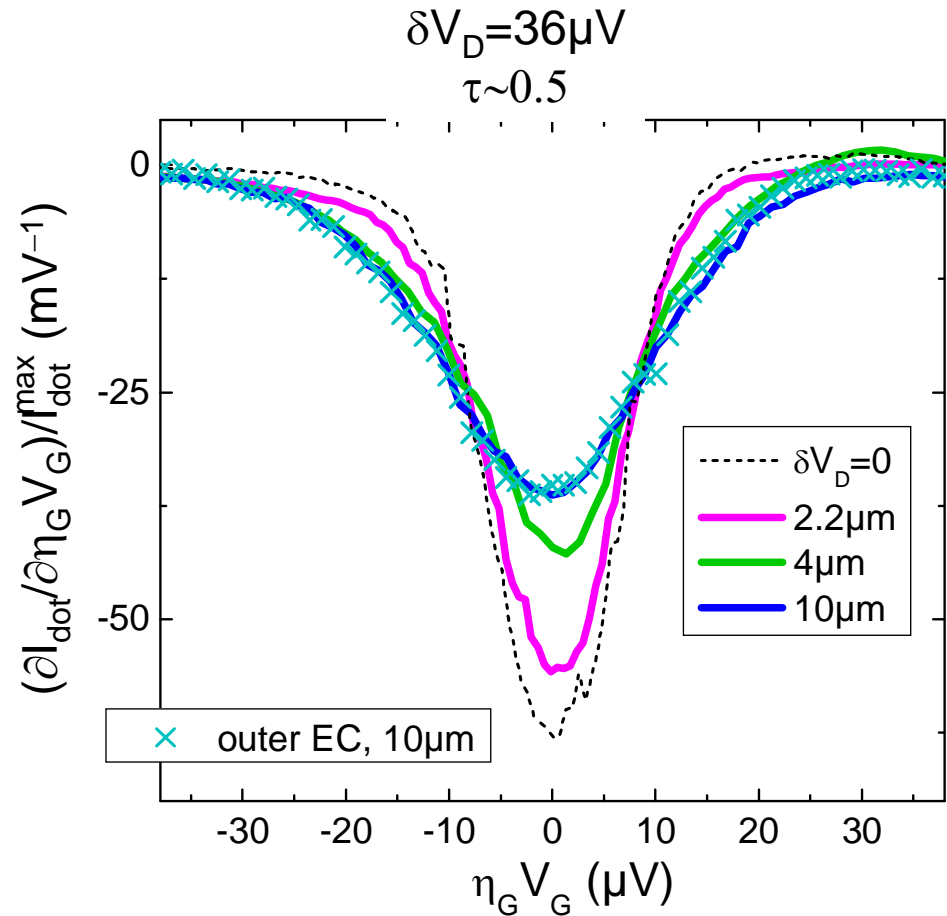

**Strong Energy Exchanges Between ECs**  
**Dominant interaction**

# What about coupling to the rest of the world?

## Confining the **inner** Edge Channel

**Closed Inner EC**  
Propagative Outer EC

**inner EC's loop**  
**CANNOT ABSORB**  
**ENERGY**  
**from Outer EC**

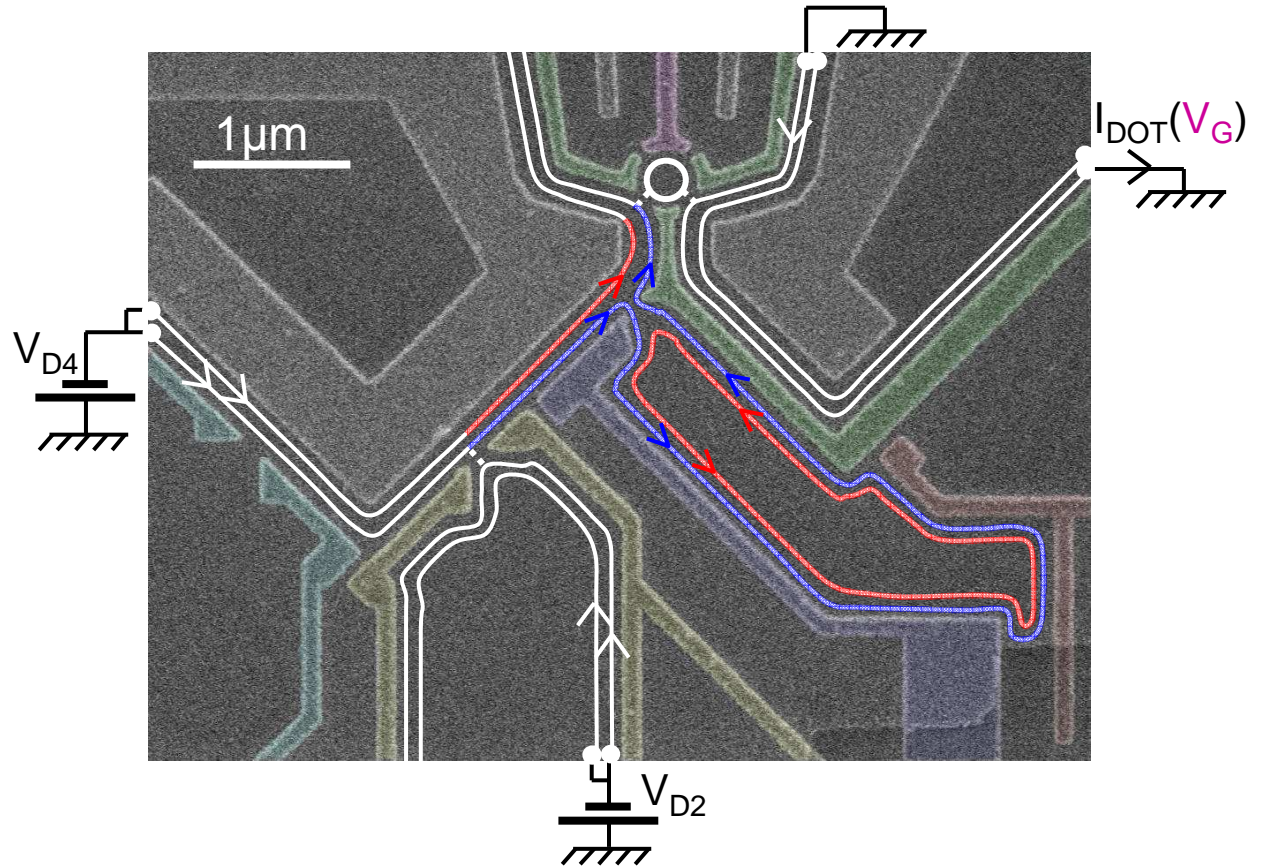

**Probes interactions of outer EC with the rest of the world**  
(metallic gates, lattice, spins etc...)

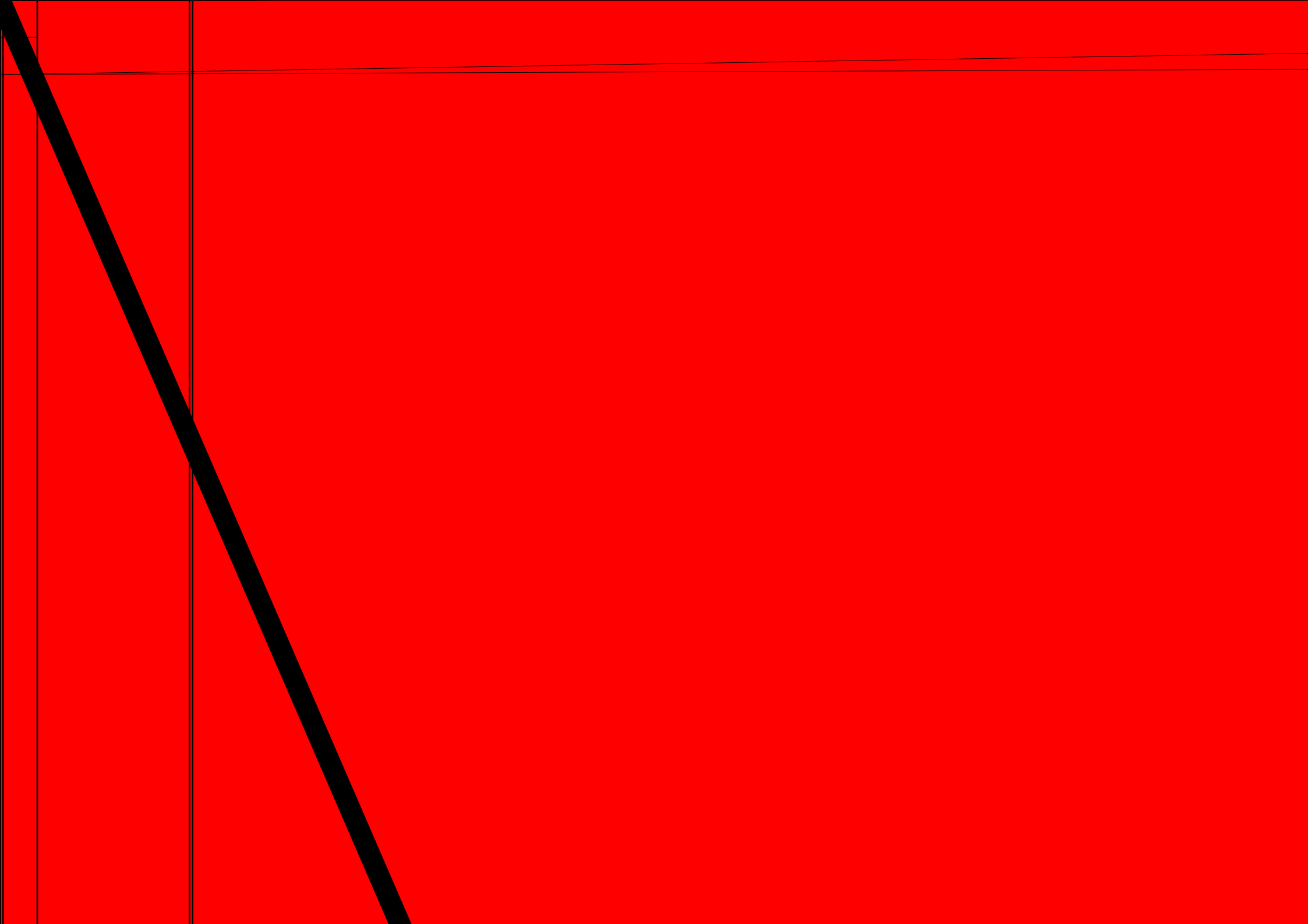



# Alternative Description of Excitations in QHR

Non-perturbative *inter* EC interactions ( $\nu=2$ )

Free bosons delocalized on both ECs  $\neq$  1D chiral fermions

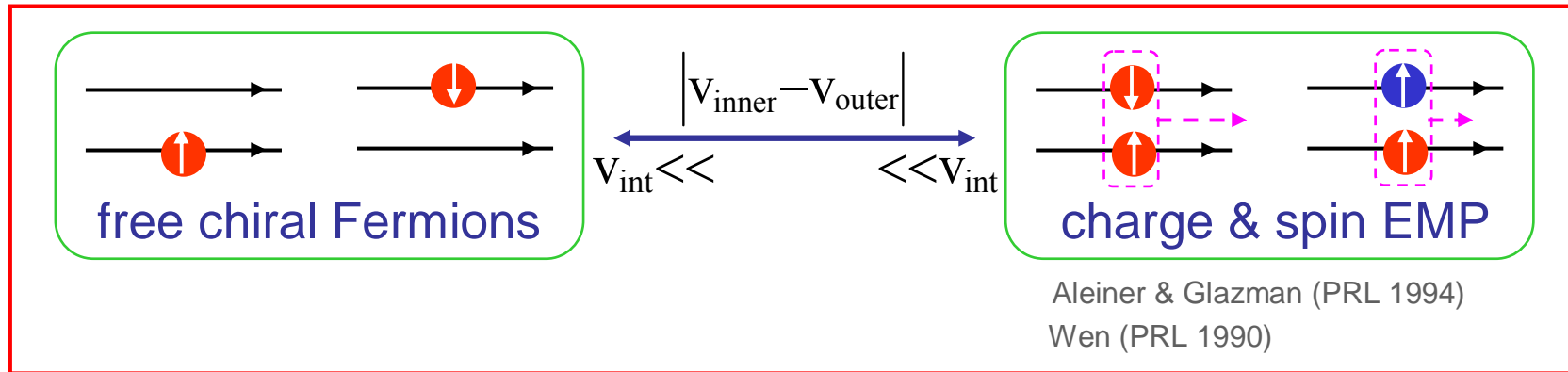

at  $\nu=2$ , equivalent to **spin-charge separation**

● QPC excites 1 EC

Levkivskyi & Sukhorukov (PRB 2008)

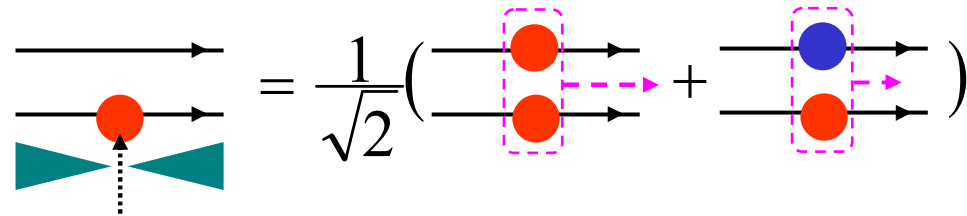

● Time evolution:

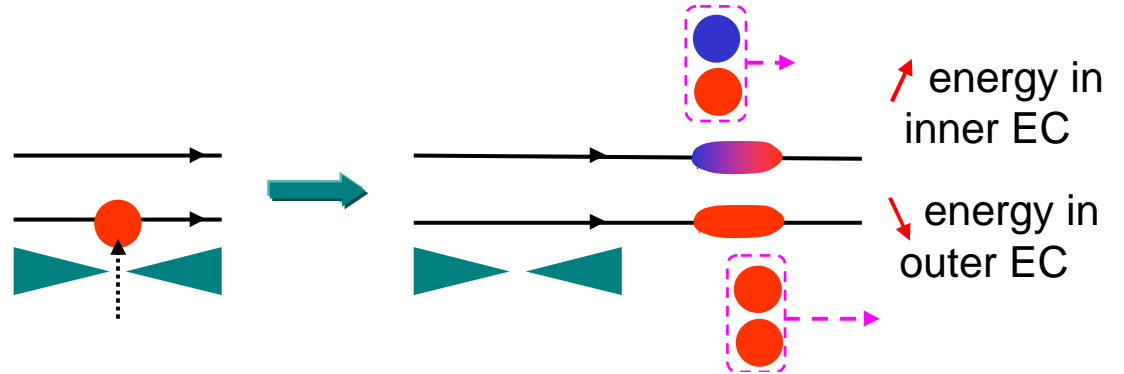

# Summary

- **A new method to tune and measure out-of-eq.  $f(E)$**

- quantum DOT : precise tool to measure  $f(E)$
- QPC : tunable source of non-eq.  $e^-$

- **Strong coupling between edge channels**

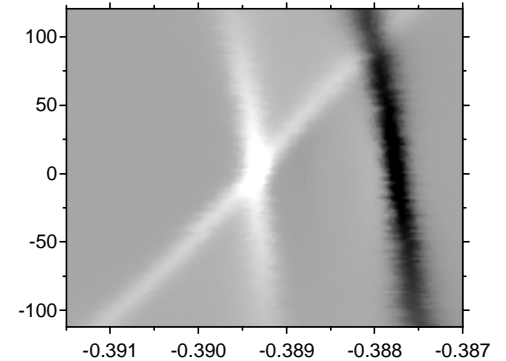
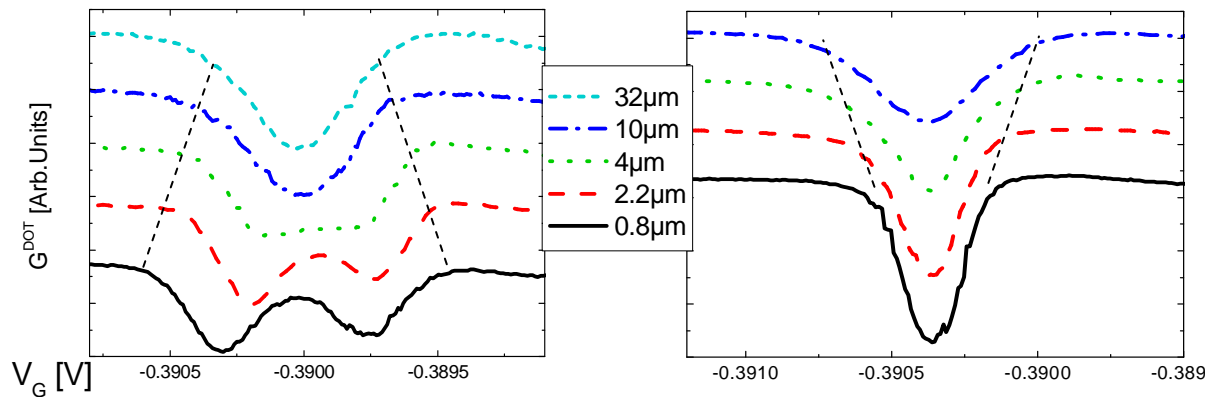

- **No energy loss at QPC, or towards other Degrees of Freedom**

(except Inner EC's internal modes)

- **Electronic excitations in the Quantum Hall Regime: collective edge modes**

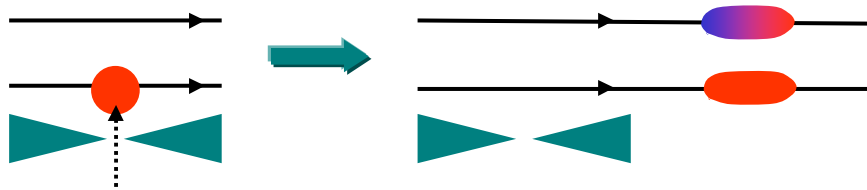

Altimiras *et al.* Nature phys. (2010)

le Sueur *et al.* submitted

- **Edge's dynamics can be freezed!**

Degiovanni *et al.* submitted

 Nano Team



Carles  
Altimiras



Ulf  
Gennser



Antonella  
Cavanna



Dominique  
Mailly

Frédéric  
Pierre

## Thanks:

Giancarlo Faini, Romain Giraud, Yong Jin



Christian Glattli, Fabien Portier, Patrice Roche, Preden Roulleau

Founding agency:

