

Radiative heat transfer at the nanoscale

Svend-Age Biehs¹, Emmanuel Rousseau², and
Jean-Jacques Greffet³

¹Institut für Physik, Oldenburg, Germany

²Laboratoire Charles Coulomb, Montpellier, France

³LCFIO, Palaiseau, France

Charge and heat dynamics in nano-systems

Orsay 10-12 Oct 2011



radiative heat transfer

- heat transfer (emissivity ϵ)

$$\rightarrow \Phi = \epsilon\sigma(T_1^4 - T_2^4)$$

- black bodies ($\epsilon = 1$)

$$\rightarrow \Phi_{\text{BB}} = \sigma(T_1^4 - T_2^4)$$

- but only for $d \gg \lambda_{\text{th}}$!!!
- for $d \ll \lambda_{\text{th}}$:
 - heat flux can exceed Φ_{BB} by orders of magnitude!
→ evanescent modes

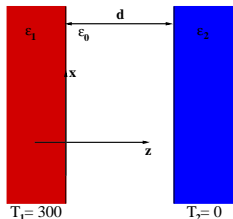

radiative heat transfer - theory

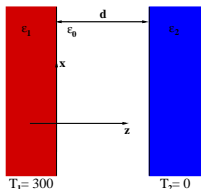

- heat flux ($T_1 = T$ and $T_2 = 0$)

$$\Phi = \int \frac{d\omega}{2\pi} \frac{\hbar\omega}{e^{\hbar\omega/(k_B T)} - 1} \int \frac{d^2\kappa}{(2\pi)^2} (\mathcal{T}_s + \mathcal{T}_p)$$

Polder and van Hove, PRB **4**, 3303 (1971)

- **metamaterials** Joulain et al., PRB **81**, 165119 (2010)
- **anisotropy** Biehs et al. Opt. Expr. **19**, A1088-A1103 (2011), APL **98** 243102 (2011)
- **roughness** Biehs & Greffet, PRB **82**, 245410 (2010)
- **sphere-sphere** Narayanaswamy & Chen, PRB **77**, 075125 (2008)
- **sphere-plane** Krüger et al., PRL **106**, 210404 (2011)
- **arbitrary geometries** Messina & Antezza PRA **84**, 042102 (2011),
- **many bodies** Ben-Abdallah et al., PRL **107**, 114301 (2011)
- ...

radiative heat transfer - experiments

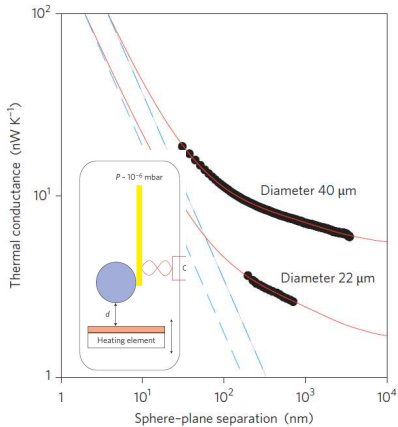

Rousseau et al., Nature Photonics **3**, 514 (2009)

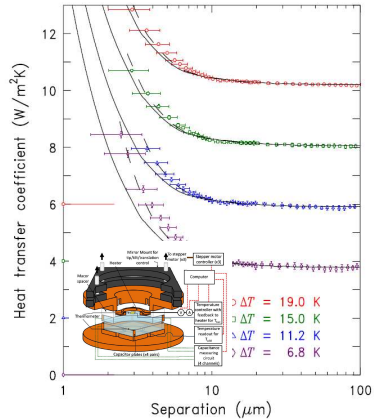

Ottens et al., PRL **107**, 014301 (2011)

radiative heat transfer

$$\Phi = \int \frac{d\omega}{2\pi} \frac{\hbar\omega}{e^{\hbar\omega/(k_B T)} - 1} \int \frac{d^2\kappa}{(2\pi)^2} (\mathcal{T}_s + \mathcal{T}_p)$$

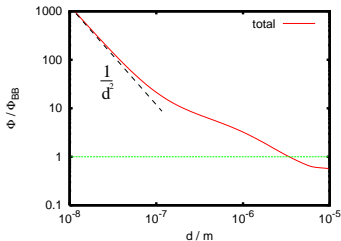
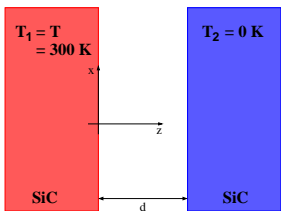

- transmission coefficient (Polder and van Hove, PRB **4**, 3303 (1971))

$$\mathcal{T}_i(\omega, \kappa; d) = \begin{cases} \frac{(1 - |r_i^{10}|^2)(1 - |r_i^{20}|^2)}{|1 - r_i^{10} r_i^{20} \exp(2ik_z d)|^2}, & \kappa < \frac{c}{d} \\ \frac{\text{Im}(r_i^{10}) \text{Im}(r_i^{20}) e^{-2|k_z|d}}{|1 - r_i^{10} r_i^{20} \exp(2ik_z d)|^2}, & \kappa > \frac{c}{d} \end{cases}$$

propagating modes

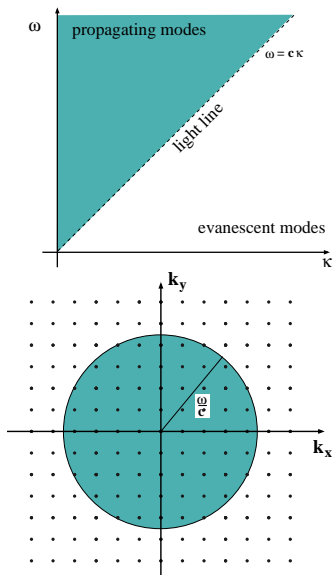

- plane wave

$$E_y = A(x, y; t)e^{ik_z z}$$

- for prop. modes $\kappa < \frac{c|\epsilon|}{c}$

$$k_z = \sqrt{\frac{\omega^2}{c^2} - \kappa^2} \in \mathbb{R}$$

- for evan. modes $\kappa > \frac{c|\epsilon|}{c}$

$$k_z = i\sqrt{\kappa^2 - \frac{\omega^2}{c^2}} \in \mathbb{C}$$

- resonant transmission

$$k_z \equiv \frac{n\pi}{d}, n \in \mathbb{N}$$

propagating modes

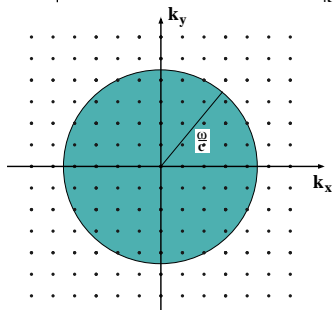
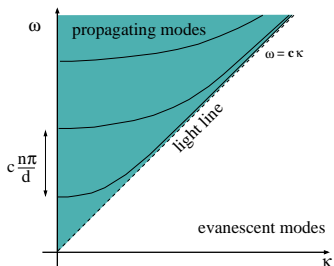

- plane wave

$$E_y = A(x, y; t)e^{ik_z z}$$

- for prop. modes $\kappa < \frac{c|\mathcal{E}}{d}$

$$k_z = \sqrt{\frac{\omega^2}{c^2} - \kappa^2} \in \mathbb{R}$$

- for evan. modes $\kappa > \frac{c|\mathcal{E}}{d}$

$$k_z = i\sqrt{\kappa^2 - \frac{\omega^2}{c^2}} \in \mathbb{C}$$

- resonant transmission

$$k_z \equiv \frac{n\pi}{d}, n \in \mathbb{N}$$

frustrated internal reflection modes

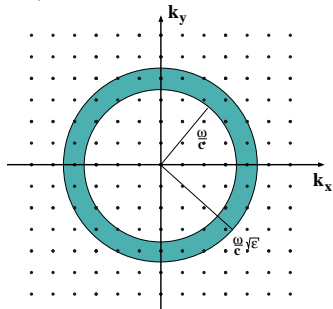
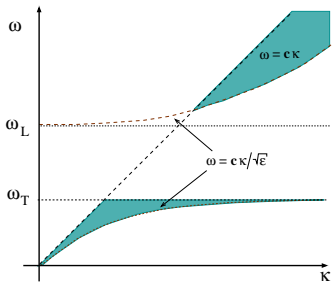

- propagating inside the bulk

$$k_{1,z} = \sqrt{\frac{\omega^2}{c^2} \epsilon - \kappa^2} \in \mathbb{R}$$

$$\Leftrightarrow \kappa < \frac{\omega}{c} \sqrt{\epsilon}$$

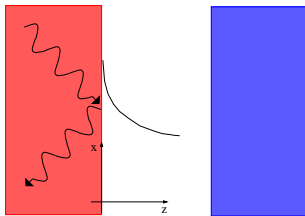

frustrated internal reflection modes

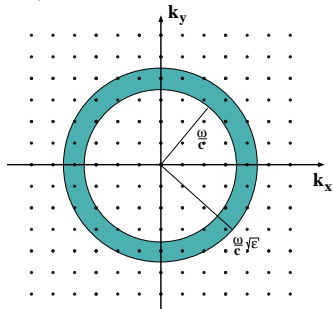
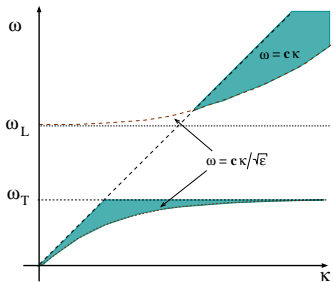

- propagating inside the bulk

$$k_{1,z} = \sqrt{\frac{\omega^2}{c^2} \epsilon - \kappa^2} \in \mathbb{R}$$

$$\Leftrightarrow \kappa < \frac{\omega}{c} \sqrt{\epsilon}$$

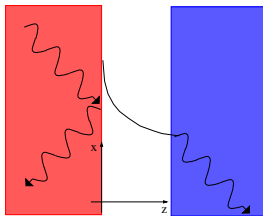

surface modes

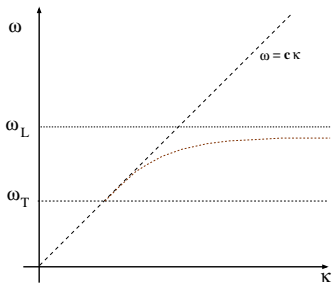

- 'bound' to the interface
- only p-polarized
- Transmission coefficient
 $\kappa \gg \omega/c$

$$\mathcal{T}_p \approx \frac{\text{Im}(r_p^{10})\text{Im}(r_p^{20})e^{-2\kappa d}}{|1 - r_p^{10}r_p^{20}\exp(-2\kappa d)|^2}$$

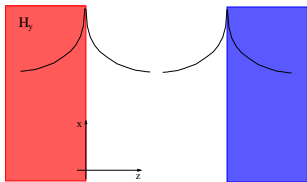
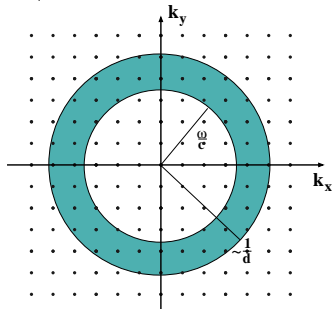

surface modes

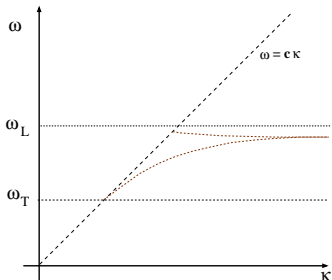

- 'bound' to the interface
- only p-polarized
- Transmission coefficient
 $\kappa \gg \omega/c$

$$\mathcal{T}_p \approx \frac{\text{Im}(r_p^{10})\text{Im}(r_p^{20})e^{-2\kappa d}}{|1 - r_p^{10}r_p^{20}\exp(-2\kappa d)|^2}$$

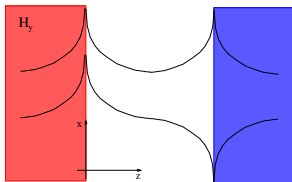
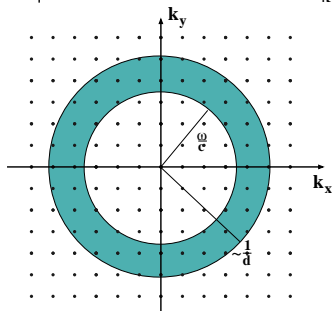

transmission coefficient (SiC)

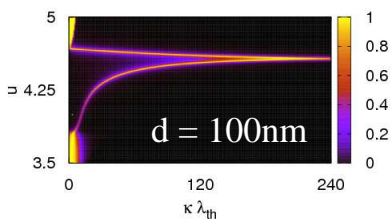
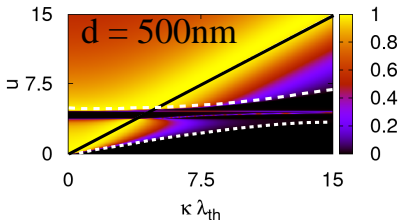
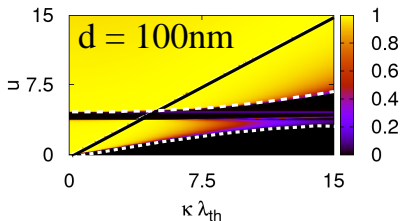
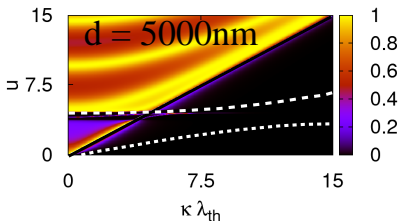

Resulting heat flux (SiC, $T_1 = 300$ K, $T_2 = 0$ K)

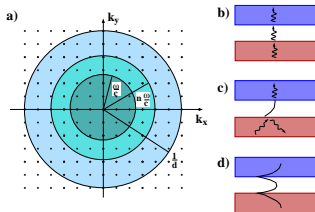
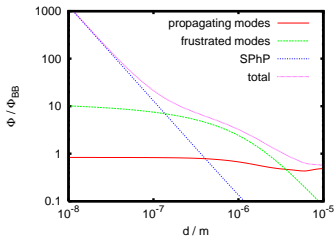

$$\Phi = \int \frac{d\omega}{2\pi} \frac{\hbar\omega}{e^{\hbar\omega/(k_B T)} - 1} \int \frac{d^2\kappa}{(2\pi)^2} (\mathcal{T}_s + \mathcal{T}_p)$$

Mesoscopic point of view

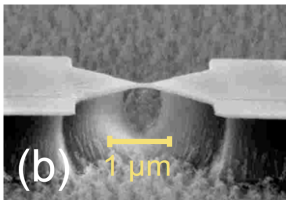

Wu et al., PRB **78**, 235421 (2008)

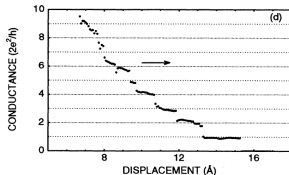

Brandbyge et al., PRB **52**, 8499 (1995)

- charge transport on mesoscopic scale (Landauer)

$$I = \Gamma V = \frac{2e^2}{h} \left[\sum_n T_n \right] V$$

- Landauer-like expression for heat radiation at nanoscale?

heat flux expression

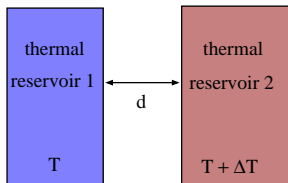

- all distances, including

$$a \ll d \ll \lambda_{\text{th}}$$

with lattice constant a

- resulting heat flux, $b(T) = \frac{1}{e^{(\hbar\omega)/(k_B T)} - 1}$

$$\Phi = \int \frac{d\omega}{2\pi} \hbar\omega [b(T + \Delta T) - b(T)] \sum_{i=s,p} \int \frac{d^2\kappa}{(2\pi)^2} \mathcal{T}_i$$

$$\Delta T \ll T$$

heat flux expression

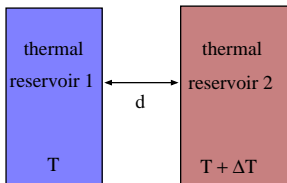

- all distances, including

$$a \ll d \ll \lambda_{\text{th}}$$

with lattice constant a

- resulting heat flux, $b(T) = \frac{1}{e^{(\hbar\omega)/(k_B T)} - 1}$

$$\Phi = \int \frac{d\omega}{2\pi} \hbar\omega \left(\frac{\partial}{\partial T} b(T) \right) \sum_{i=s,p} \int \frac{d^2\kappa}{(2\pi)^2} \mathcal{T}_i \Delta T$$

$$\Delta T \ll T$$

heat flux expression

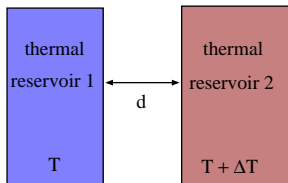

- all distances, including

$$a \ll d \ll \lambda_{\text{th}}$$

with lattice constant a

- resulting heat flux, $b(T) = \frac{1}{e^{(\hbar\omega)/(k_B T)} - 1}$

$$\Phi = \frac{k_B^2 T}{h} \int du u^2 \left(-\frac{\partial}{\partial u} b(u) \right) \sum_{i=s,p} \int \frac{d^2 \kappa}{(2\pi)^2} \mathcal{T}_i \Delta T$$

introducing $u = \hbar\omega / (k_B T)$

heat flux expression

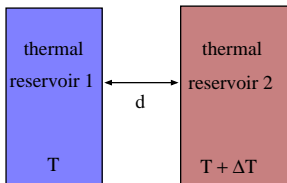

- all distances, including

$$a \ll d \ll \lambda_{\text{th}}$$

with lattice constant a

- resulting heat flux, $b(T) = \frac{1}{e^{(\hbar\omega)/(k_B T)} - 1}$

$$\Phi = \frac{k_B^2 T}{h} \sum_{i=s,p} \int \frac{d^2 \kappa}{(2\pi)^2} \left[\int du u^2 \left(-\frac{\partial}{\partial u} b(u) \right) \mathcal{T}_i \right] \Delta T$$

interchanging integrals

heat flux expression

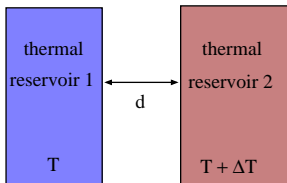

- all distances, including

$$a \ll d \ll \lambda_{\text{th}}$$

with lattice constant a

- resulting heat flux, $b(T) = \frac{1}{e^{(\hbar\omega)/(k_B T)} - 1}$

$$\Phi = \frac{k_B^2 T}{h} \sum_{i=s,p} \int \frac{d^2 \kappa}{(2\pi)^2} \left[\frac{\int du u^2 \left(-\frac{\partial}{\partial u} b(u) \right) \mathcal{T}_i}{\int du u^2 \left(-\frac{\partial}{\partial u} b(u) \right)} \int du u^2 \left(-\frac{\partial}{\partial u} b(u) \right) \right] \Delta T$$

introduce $\int du u^2 \left(-\frac{\partial}{\partial u} b(u) \right) = \pi^2/3$

heat flux expression

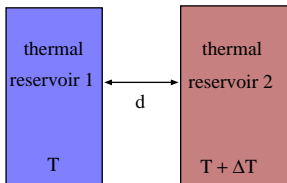

- all distances, including

$$a \ll d \ll \lambda_{\text{th}}$$

with lattice constant a

- resulting heat flux, $b(T) = \frac{1}{e^{(\hbar\omega)/(k_B T)} - 1}$

$$\Phi = \frac{k_B^2 T}{h} \sum_{i=s,p} \int \frac{d^2 \kappa}{(2\pi)^2} \left[\frac{\int du u^2 \left(-\frac{\partial}{\partial u} b(u) \right) \mathcal{T}_i}{\int du u^2 \left(-\frac{\partial}{\partial u} b(u) \right)} \frac{\pi^2}{3} \right] \Delta T$$

introduce $\int du u^2 \left(-\frac{\partial}{\partial u} b(u) \right) = \pi^2/3$

heat flux expression

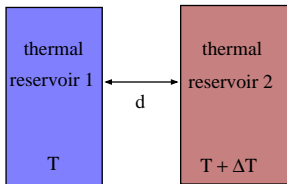

- all distances, including

$$a \ll d \ll \lambda_{\text{th}}$$

with lattice constant a

- resulting heat flux, $b(T) = \frac{1}{e^{(\hbar\omega)/(k_B T)} - 1}$

$$\Phi = \frac{\pi^2 k_B^2 T}{3h} \sum_{i=s,p} \int \frac{d^2 \kappa}{(2\pi)^2} \left[\frac{\int du u^2 \left(-\frac{\partial}{\partial u} b(u) \right) \mathcal{T}_i}{\int du u^2 \left(-\frac{\partial}{\partial u} b(u) \right)} \right] \Delta T$$

defining $\bar{\mathcal{T}}_i \equiv \frac{\int du u^2 \left(\frac{\partial}{\partial u} b(u) \right) \mathcal{T}_i}{\int du u^2 \left(\frac{\partial}{\partial u} b(u) \right)}$

heat flux expression

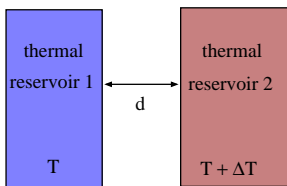

- all distances, including

$$a \ll d \ll \lambda_{\text{th}}$$

with lattice constant a

- resulting heat flux, $b(T) = \frac{1}{e^{(\hbar\omega)/(k_B T)} - 1}$

$$\Phi = \frac{\pi^2 k_B^2 T}{3h} \left[\sum_{i=s,p} \int \frac{d^2 \kappa}{(2\pi)^2} \bar{\mathcal{T}}_i \right] \Delta T$$

defining $\bar{\mathcal{T}}_i \equiv \frac{\int du u^2 \left(\frac{\partial}{\partial u} b(u) \right) \mathcal{T}_i}{\int du u^2 \left(\frac{\partial}{\partial u} b(u) \right)}$

Landauer-like heat flux expression

- final result

$$\Phi = \frac{\pi^2 k_B^2 T}{3h} \left[\sum_{i=s,p} \int \frac{d^2 \kappa}{(2\pi)^2} \bar{T}_i \right] \Delta T \quad \leftrightarrow \quad I = \Gamma V = \frac{2e^2}{h} \left[\sum_n T_n \right] V$$

- quantum of thermal conductance

$$\frac{\pi^2 k_B^2 T}{3h}$$

Pendry, J. Phys. A **16**, 2161 (1983)

- mean transmission coefficient

$$\bar{T}_i = \frac{\int du u^2 \left(\frac{\partial}{\partial u} b(u) \right) T_i}{\int du u^2 \left(\frac{\partial}{\partial u} b(u) \right)}$$

mean transmission coefficient

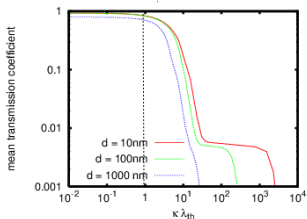

$$\Phi = \frac{\pi^2 k_B^2 T}{3h} \sum_{i=s,p} \int \frac{d^2 \kappa}{(2\pi)^2} \bar{T}_i \Delta T$$

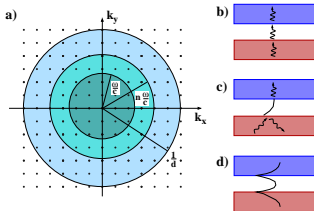
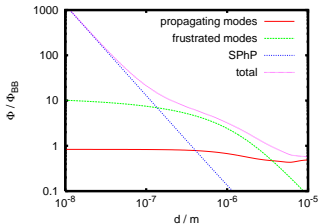

Biehs et al., PRL **105**, 234301 (2010)

mean transmission coefficient

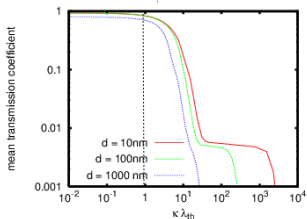

$$\Phi = \frac{\pi^2 k_B^2 T}{3h} \sum_{i=s,p} \int \frac{d^2 \kappa}{(2\pi)^2} \bar{T}_i \Delta T$$

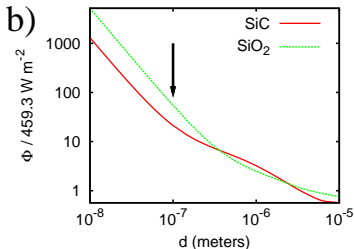
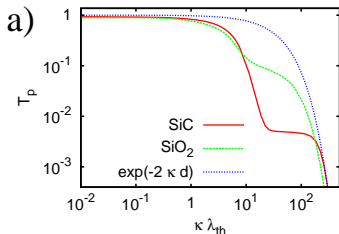

Summary/Conclusions

- Introduction to nanoscale heat transfer
 - propagating modes
 - frustrated internal reflection modes
 - coupled surface phonon polaritons
- Landauer-like expression
 - highlights number of contributing modes
 - tradeoff between NOM and transmission
 - fundamental limit of near-field heat flux

P. Ben-Abdallah and K. Joulain, PRB **82**, 121419 (R)(2010)

Thanks for your attention !!!

Fluctuational electrodynamics (Rytov)

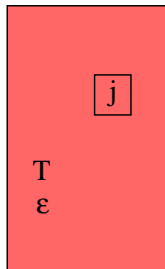

- Maxwell's Eqs. + fluct. currents

$$\langle \mathbf{j} \rangle = \mathbf{0}$$

- fluctuating fields

$$E_{\alpha}(\omega, \mathbf{r}) = i\omega\mu_0 \int_V d^3r' G_{\alpha\beta}(\mathbf{r}, \mathbf{r}') j_{\beta}(\mathbf{r}, \omega)$$

- fluctuation dissipation theorem

$$\langle j_{\alpha}(\mathbf{r}) j_{\beta}^*(\mathbf{r}') \rangle = \frac{\hbar\omega}{e^{\hbar\omega/k_B T} - 1} [\text{Im}(\epsilon)\delta_{\alpha\beta}\delta(\mathbf{r} - \mathbf{r}')]]$$

- Correlation functions of the fields

$$\langle E_{\alpha} E_{\beta}^* \rangle, \langle H_{\alpha} H_{\beta}^* \rangle, \langle E_{\alpha} H_{\beta}^* \rangle$$

Landauer expression

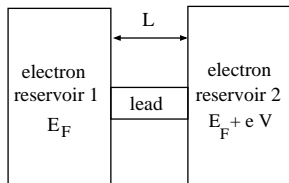

- mesoscopic system

$$l_e, l_\varphi \ll \text{rel. length scales}$$

- resulting current (env), $f(E) = \frac{1}{e^{(E-E_F)/(k_B T)} + 1}$

$$I = e \int dk n(k) v_k [f(E - eV) - f(E)] \sum_n T_n(E)$$

$$n(k)dk = 2 \frac{1}{L} \frac{dk}{2\pi} = 2 \frac{dk}{2\pi}$$

Landauer expression

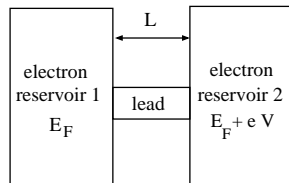

- mesoscopic system

$$l_e, l_\varphi \ll \text{rel. length scales}$$

- resulting current (env), $f(E) = \frac{1}{e^{(E-E_F)/(k_B T)} + 1}$

$$I = e \int dk n(k) v_k [f(E - eV) - f(E)] \sum_n T_n(E)$$

$$n(k)dk = 2 \frac{1}{L} \frac{dk}{2\pi} = 2 \frac{dk}{2\pi}$$

Landauer expression

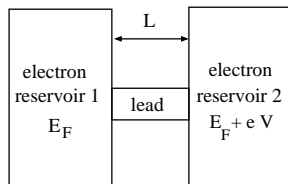

- mesoscopic system

$$l_e, l_\varphi \ll \text{rel. length scales}$$

- resulting current (env), $f(E) = \frac{1}{e^{(E-E_F)/(k_B T)} + 1}$

$$I = 2e \int \frac{dk}{2\pi} v_k [f(E - eV) - f(E)] \sum_n T_n(E)$$

$$v_k = \frac{1}{\hbar} \frac{\partial E}{\partial k}$$

Landauer expression

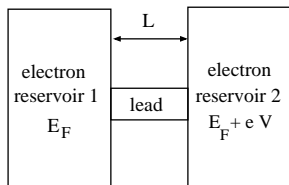

- mesoscopic system

$$l_e, l_\varphi \ll \text{rel. length scales}$$

- resulting current (env), $f(E) = \frac{1}{e^{(E-E_F)/(k_B T)} + 1}$

$$I = 2e \int \frac{dk}{2\pi} v_k [f(E - eV) - f(E)] \sum_n T_n(E)$$

$$v_k = \frac{1}{\hbar} \frac{\partial E}{\partial k}$$

Landauer expression

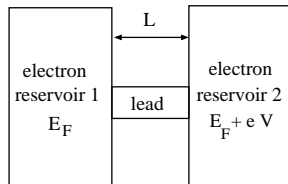

- mesoscopic system

$$l_e, l_\varphi \ll \text{rel. length scales}$$

- resulting current (env), $f(E) = \frac{1}{e^{(E-E_F)/(k_B T)} + 1}$

$$I = 2e \int \frac{dk}{2\pi} \frac{1}{\hbar} \frac{\partial E}{\partial k} [f(E - eV) - f(E)] \sum_n T_n(E)$$

$$v_k = \frac{1}{\hbar} \frac{\partial E}{\partial k}$$

Landauer expression

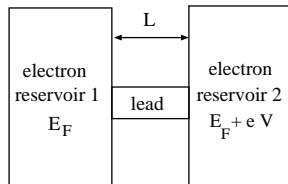

- mesoscopic system

$$l_e, l_\varphi \ll \text{rel. length scales}$$

- resulting current (env), $f(E) = \frac{1}{e^{(E-E_F)/(k_B T)} + 1}$

$$I = \frac{2e}{h} \int dk \frac{\partial E}{\partial k} [f(E - eV) - f(E)] \sum_n T_n(E)$$

Landauer expression

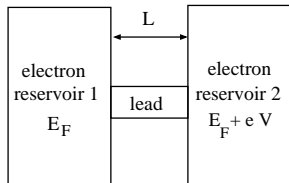

- mesoscopic system

$$l_e, l_\varphi \ll \text{rel. length scales}$$

- resulting current (env), $f(E) = \frac{1}{e^{(E-E_F)/(k_B T)} + 1}$

$$I = \frac{2e}{h} \int dE [f(E - eV) - f(E)] \sum_n T_n(E)$$

$$eV \ll E_F$$

Landauer expression

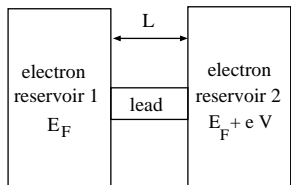

- mesoscopic system

$$l_e, l_\varphi \ll \text{rel. length scales}$$

- resulting current (env), $f(E) = \frac{1}{e^{(E-E_F)/(k_B T)} + 1}$

$$I = \frac{2e}{h} \int dE \left[-\frac{\partial}{\partial E} f(E) \right] \sum_n T_n(E) eV$$

$$k_B T \ll E_F$$

Landauer expression

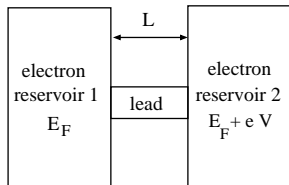

- mesoscopic system

$$l_e, l_\varphi \ll \text{rel. length scales}$$

- resulting current (env), $f(E) = \frac{1}{e^{(E-E_F)/(k_B T)} + 1}$

$$I = \frac{2e^2}{h} \left[\sum_n T_n(E_F) \right] V$$

NSThM

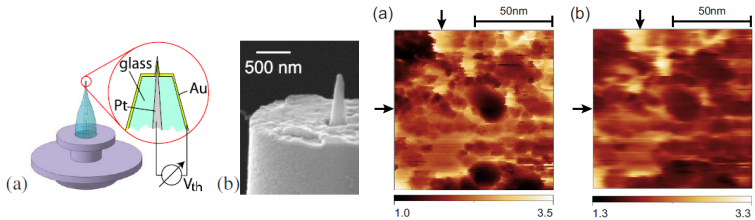

Kittel et al., APL **93**, 193109 (2008)