



Spontaneous Workshop VI, Cargèse • May 11, 2012

# Search for Matter-Antimatter Transformation with Cold Neutrons

Yuri Kamyshev/ University of Tennessee  
email: [kamyshev@utk.edu](mailto:kamyshev@utk.edu)

# Overview

- ❖ Observation of violation of Baryon number is one of the pillars of Cosmology:
  - it is required for Matter-Antimatter asymmetry explanation BAU (Sakharov)
  - it follows from the inflation (Dolgov, Zeldovich)
  - it is motivated by GUT models
- ❖ Proton decay with  $\Delta B = 1$  so far has failed to demonstrate existence of BV
- ❖  $(B - L)$  must be violated  $\rightarrow$  idea of Leptogenesis with  $\Delta L = 2$ .  
Majorana nature of  $\nu$ 's should experimentally demonstrate  $\Delta L = 2$ ,  
however experimental prove of Leptogenesis will be hardly possible.
- ❖ Alternative search is  $n \rightarrow \bar{n}$  transformation with  $\Delta B = 2$  and  $(B - L)V$
- ❖ New developments in  $NN\bar{b}$  search within "Project X"

# Can Neutron be a Majorana Particle?

In the famous E. Majorana 1937 paper  
“Teoria simmetrica dell’elettrone e del positrone”,  
Il Nuovo Cimento, v.14, 1937, pp. 171-184:

“ ... this method ... allows not only to cast the  
electron-positron theory into a symmetric form,  
but also to construct an essentially new theory  
for particles not endowed with an electric charge  
(neutrons and the hypothetical neutrinos).”

(translated by L. Maiani)



But antineutron discovered in 1956 by B. Cork et al. @ LBL was turned out  
to be a particle different from neutron.

However, the presence of some small fraction of the antineutron component in  
the neutron wave function can not be excluded, and the question whether  
neutron is Majorana particle should remain.

This mixing fraction must be small (otherwise it would be already observed)  
unless there are some suppression conditions or mechanisms present.



## Mixing of neutral components is a general feature observed in Nature:

- ❖ Such mixing occurs when some symmetry is broken
- Gauge symmetry  $\rightarrow$  mixing of  $U(1) \times SU(2)$  in SM  $Z^0$  and  $\gamma$
- Strangeness, beauty  $\rightarrow$  in  $K^0 \rightarrow \bar{K}^0, B^0 \rightarrow \bar{B}^0$
- Flavor number  $\rightarrow$  in neutrino flavor oscillation  $\nu_\mu \rightarrow \nu_e$
- Lepton number  $\rightarrow$  in Majorana neutrinos  $\nu_e \rightarrow \bar{\nu}_e$
- Baryon number  $\rightarrow n \rightarrow \bar{n}$

# B, L, and B – L

---

- ❖ e.g.  $n \rightarrow p + e^- + \bar{\nu}_e$  conserves B and L:  $\Delta B=0$  and  $\Delta L=0$
- ❖ B and L are “accidental symmetries”  $\rightarrow$  might be violated:  $\Delta B, \Delta L \geq 1$
- ❖  $\Delta B$  and  $\Delta L$  are connected via conservation of angular momentum.  
 $\Delta L = \pm \Delta B$  . Is  $(B - L)$  conserved?
- ❖ Naively  $(B - L)$  is strongly violated in regular matter:  $\#n + \#p - \#e \neq 0$   
However, on the scale of the universe it might be compensated by the unknown number of relic neutrinos and antineutrinos ...
- ❖ Standard Model conserves  $(B - L)$  but violates B, L and  $(B+L)$  at tiny level [G. 't Hooft, Nobel Prize, 1999];  
at electroweak scale fast  $(B+L)$  violation would wipe out BAU if the latter is due to  $(B - L)$  conservation processes at GUT scale [V. Kuzmin, A. Rubakov, M. Shaposhnikov, 1985].
- ❖ That was a starting point for the models of Leptogenesis.

# Proton Decay Searches

are motivated by (B-L) conserving models

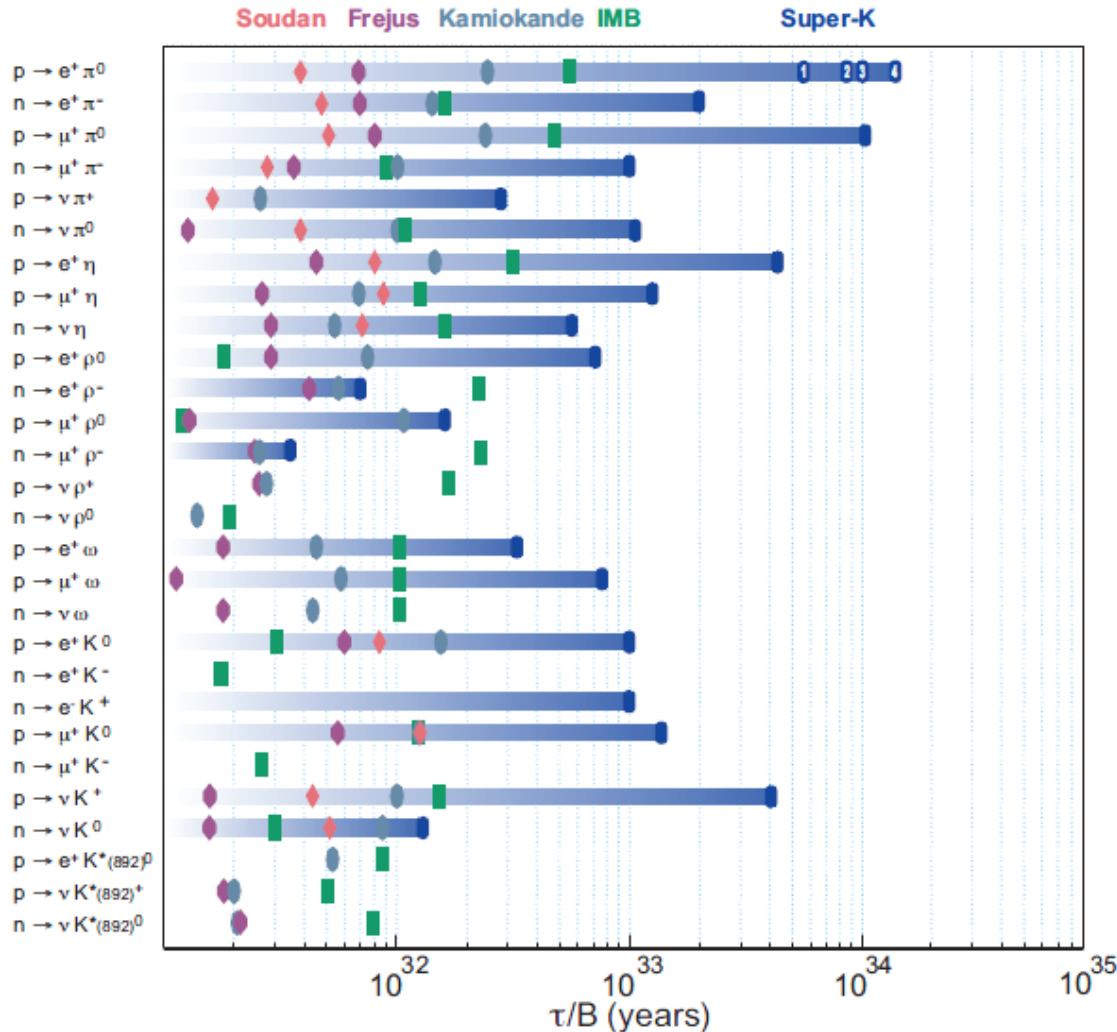

J. L. Raaf @ IF-2011

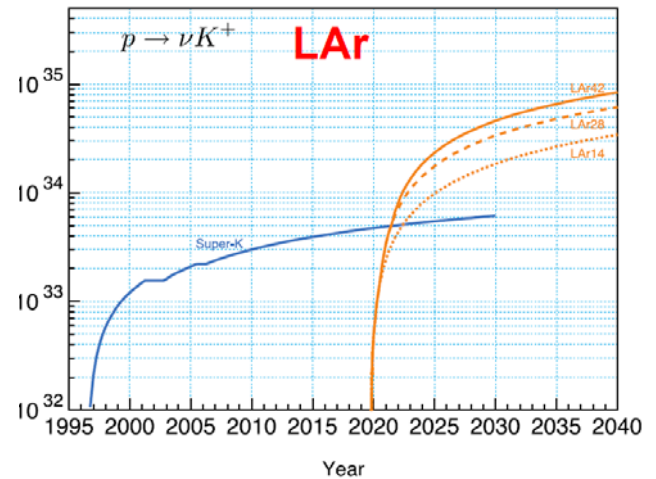
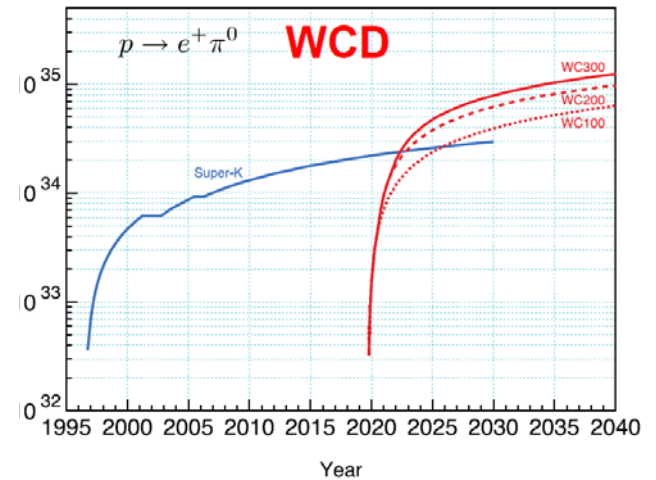

LBNE Physics Working Group Report  
arXiv:1110.6249v1 [hep-ex]

“Proton decay is not a prediction of baryogenesis.” [Yanagida, 2002]

# New searches for B, L, B – L violation

- ❖ Several experiments are currently searching for Majorana neutrino in “neutrinoless double beta decay”. Majorana neutrinos means  $\nu \leftrightarrow \bar{\nu}$  and  $\Delta L = 2$ , thus violating (B – L) by 2.

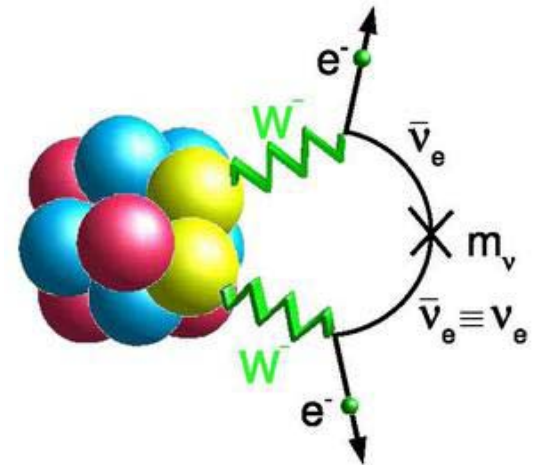

- ❖ If (B – L) is violated by 2 that also means that  $\Delta B=2$  should exist and thus  $n \leftrightarrow \bar{n}$  is possible

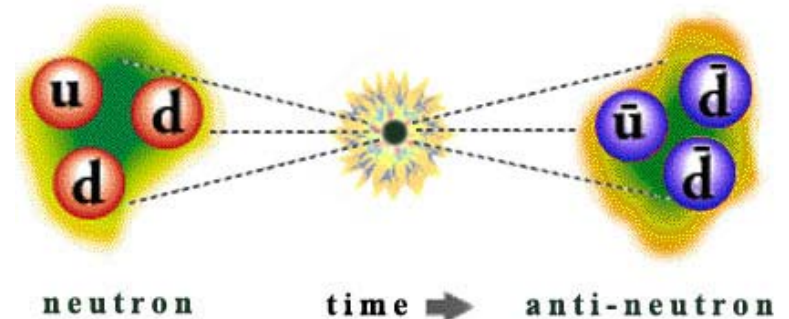

# Some history of $n \leftrightarrow \bar{n}$ ideas

---

- ❖ There are no laws of nature that would forbid the  $N \leftrightarrow Nbar$  transitions except the conservation of "*baryon charge (number)*"

*M. Gell-Mann and A. Pais, Phys. Rev. 97 (1955) 1387*

*L. Okun, Weak Interaction of Elementary Particles, Moscow, 1963*

- ❖  $N \leftrightarrow Nbar$  -like process was suggested as a possible mechanism for explanation of Baryon Asymmetry of Universe

*V. Kuzmin, 1970*

- ❖  $N \leftrightarrow Nbar$  works within GUT + SUSY ideas. First considered and developed within the framework of L/R symmetric Unification models

*R. Mohapatra and R. Marshak, 1979 ...*

- ❖ Recent models explaining neutrino masses, low-scale baryogenesis, connecting with dark matter, involving gravity, extra-Ds, predicting new particles at LHC...

*K. Babu, R. Mohapatra et al; Z. Berezhiani et al;*

*A. Dolgov et al; G. Dvali and G. Gabadadze, ...*



# Scales of $n \rightarrow \bar{n}$ $(B - L)V$

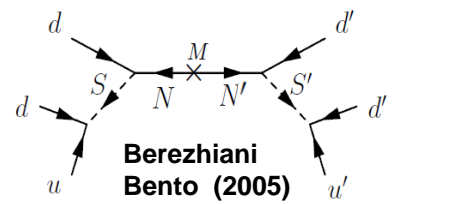
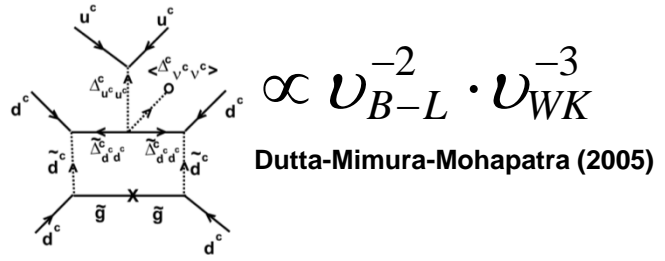
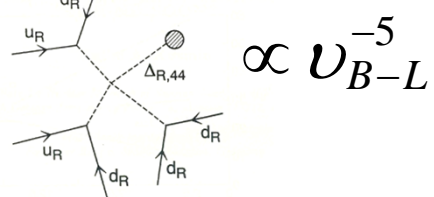
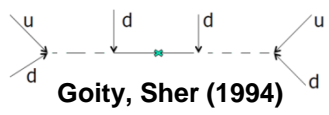
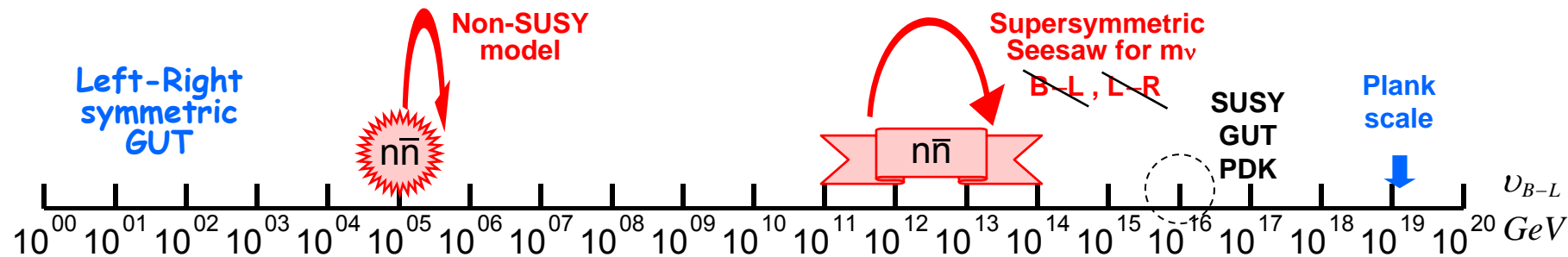

Baryogenesis at TeV scale

Berezhiani et al (2005)  
Babu et al (2006)  
Dolgov et al (2006)

**Experimental motivation!**  
large increase of sensitivity:  
factor of  $\times 1,000$  is possible

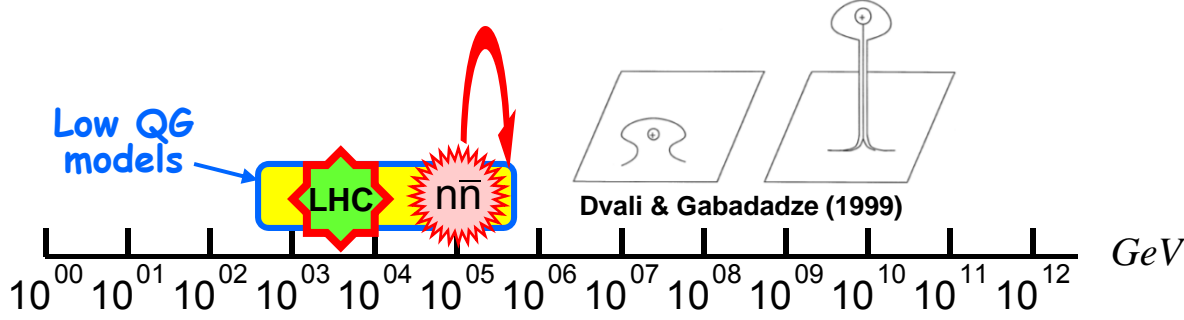

## $n \rightarrow \bar{n}$ transition probability

---

$$\Psi = \begin{pmatrix} n \\ \bar{n} \end{pmatrix} \quad \text{mixed } n\text{-}\bar{n} \text{ QM state}$$

$$H = \begin{pmatrix} E_n & \alpha \\ \alpha & E_{\bar{n}} \end{pmatrix}$$

$$E_n = m_n + U_n \quad ; \quad E_{\bar{n}} = m_{\bar{n}} + U_{\bar{n}}$$

$$U_{n,\bar{n}} = U_0 \pm V \quad \leftarrow \text{part different for } n \text{ and } \bar{n}$$

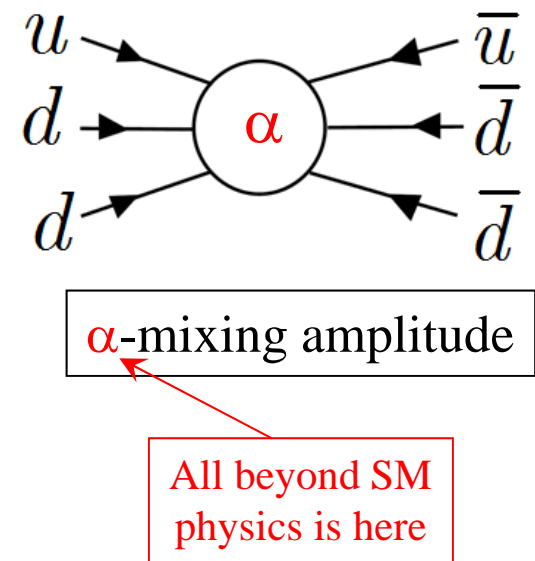

$$P_{n \rightarrow \bar{n}}(t) = \frac{\alpha^2}{\alpha^2 + V^2} \cdot \sin^2 \left( \frac{\sqrt{\alpha^2 + V^2}}{\hbar} \cdot t \right)$$

where  $V$  is a potential symmetrically different for  $n$  and  $\bar{n}$   
 (e.g. due to non-compensated Earth mag. field, or nuclear potential);  
 $t$  is observation time in an experiment.

In ideal situation of no suppression i.e.  
 "vacuum oscillations" :  $V = 0$   
 and experimentally  $t \sim 0.1 \text{ s}$  to  $10 \text{ s}$

$$P_{n \rightarrow \bar{n}} = \left( \frac{\alpha}{\hbar} \times t \right)^2 = \left( \frac{t}{\tau_{n\bar{n}}} \right)^2$$

$\tau_{n\bar{n}} = \frac{\hbar}{\alpha}$  is characteristic "oscillation" time [ $\alpha < 2 \cdot 10^{-24} \text{ eV}$ , as presently known]

Predictions of theoretical models: observable effect around  $\alpha \sim 10^{-25} - 10^{-26} \text{ eV}$

Sensitivity (or figure of merit) is  $\rightarrow N_n \times \bar{t}^2$

$$P \propto N \cdot \left(\frac{t}{\tau}\right)^2$$

Let's try to configure such an experiment

- Concept: after time  $t$  some of the neutrons might be spontaneously converted to antineutrons and will annihilate with the matter producing a star of pions.
- Need many neutrons: reactor or spallation source ← Produced as  $\sim 2$  MeV
- Slowest possible neutrons with maximum observation time ← Even moderated to 300K  $v_n \sim 2,200$  m/s with broad Maxwell-Boltzmann spectrum
- Earth magnetic field shielding:  $2\mu B < \frac{\hbar}{t} \rightarrow B < 1 - 10$  nT
- Vacuum  $< 10^{-5}$  Pa
- Distance ? Doesn't matter here →
- Gravity effect on horizontal beam

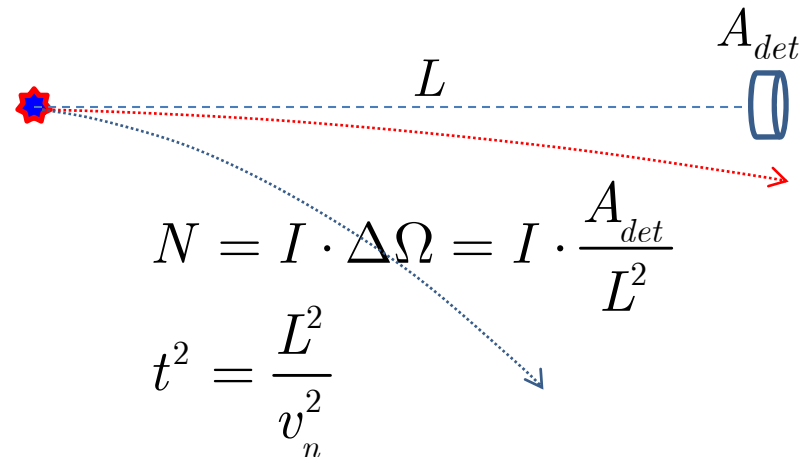

# Previous n-nbar search experiment with free neutrons

At ILL/Grenoble reactor in 89-91 by Heidelberg-ILL-Padova-Pavia Collaboration

M. Baldo-Ceolin et al., Z. Phys., C63 (1994) 409

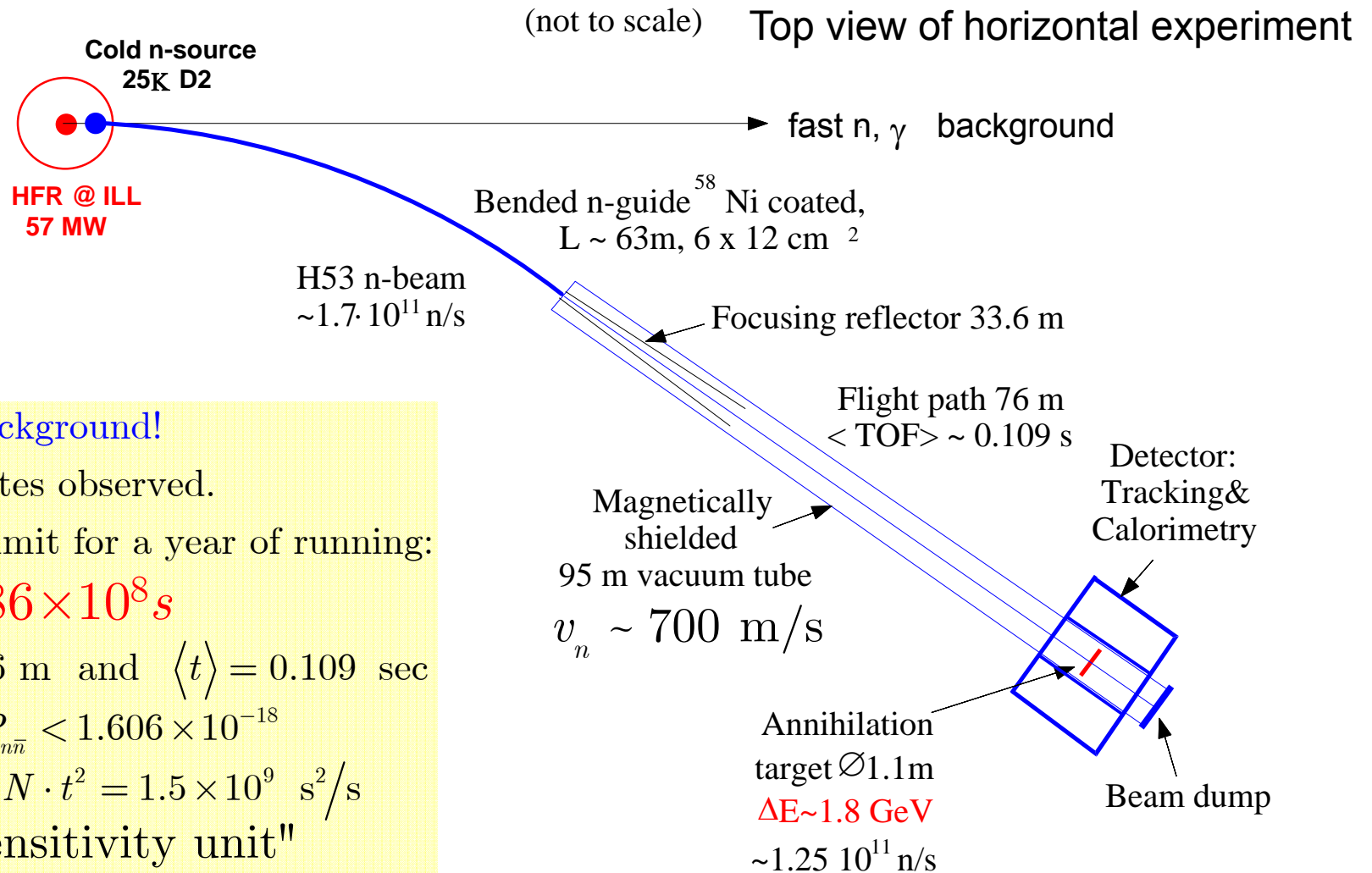

No GeV background!

No candidates observed.

Measured limit for a year of running:

$$\tau_{n\bar{n}} > 0.86 \times 10^8 \text{ s}$$

with L  $\sim 76$  m and  $\langle t \rangle = 0.109$  sec

measured  $P_{n\bar{n}} < 1.606 \times 10^{-18}$

sensitivity:  $N \cdot t^2 = 1.5 \times 10^9$  s $^2$ /s

$\doteq$  "ILL sensitivity unit"

## $n \rightarrow \bar{n}$ for bound $n$ inside nuclei is strongly suppressed

---

Neutrons inside nuclei are "free" for the time:  $\Delta t \sim \frac{\hbar}{E_{well}} \sim \frac{\hbar}{30 MeV} \sim 2.2 \times 10^{-23} s$

each oscillating with "free" probability  $= \left( \frac{\Delta t}{\tau_{n\bar{n}}} \right)^2$

and "experiencing free condition"  $N = \frac{1}{\Delta t}$  times per second.

Transformation probability per second:  $P_A = \frac{1}{\tau_A} = \left( \frac{\Delta t}{\tau_{n\bar{n}}} \right)^2 \times \left( \frac{1}{\Delta t} \right)$  (V.Kuzmin)

Intranuclear (exponential) lifetime:

$$\tau_A = \frac{\tau_{n\bar{n}}^2}{\Delta t} = R \times \tau_{n\bar{n}}^2$$

where  $R \sim \frac{1}{\Delta t} \sim 4.5 \times 10^{22} s^{-1}$  is "nuclear suppression factor"

Actual nuclear theory suppression calculations for  $^{16}O, ^2D, ^{56}Fe, ^{40}Ar$  by C. Dover et al; W.Alberico et al; B.Kopeliovich and J. Hufner, and most recently by Friedman and Gal (2008) for  $^{16}O$  with correction of factor of  $\times 2$  to the previous

$$R(\text{Oxygen}) \approx 5 \times 10^{22} s^{-1} (\pm 15\%)$$

(Friedman and Gal, 2008)

## Bound neutron N-Nbar search experiments

Experiment	Year	A	n-year ( $10^{32}$ )	Det. eff.	Candid.	Bkgr.	$\tau_{\text{nucl}}$ , yr (90% CL)
Kamiokande	1986	O	3.0	33%	0	0.9/yr	$>0.43 \times 10^{32}$
Frejus	1990	Fe	5.0	30%	0	4	$>0.65 \times 10^{32}$
Soudan-2	2002	Fe	21.9	18%	5	4.5	$>0.72 \times 10^{32}$
Super-K	2007	O	245.4	10.4%	20	21.3	$>1.8 \times 10^{32}$
Super-K	2009	O	254.5	12%	23	24	$>1.97 \times 10^{32}$
SNO *	2010	D	0.54	41%	2	4.75	$>0.301 \times 10^{32}$
Super-K	2011	O	245	12.1%	24	24.1	$>1.89 \times 10^{32}$

\* Not yet published

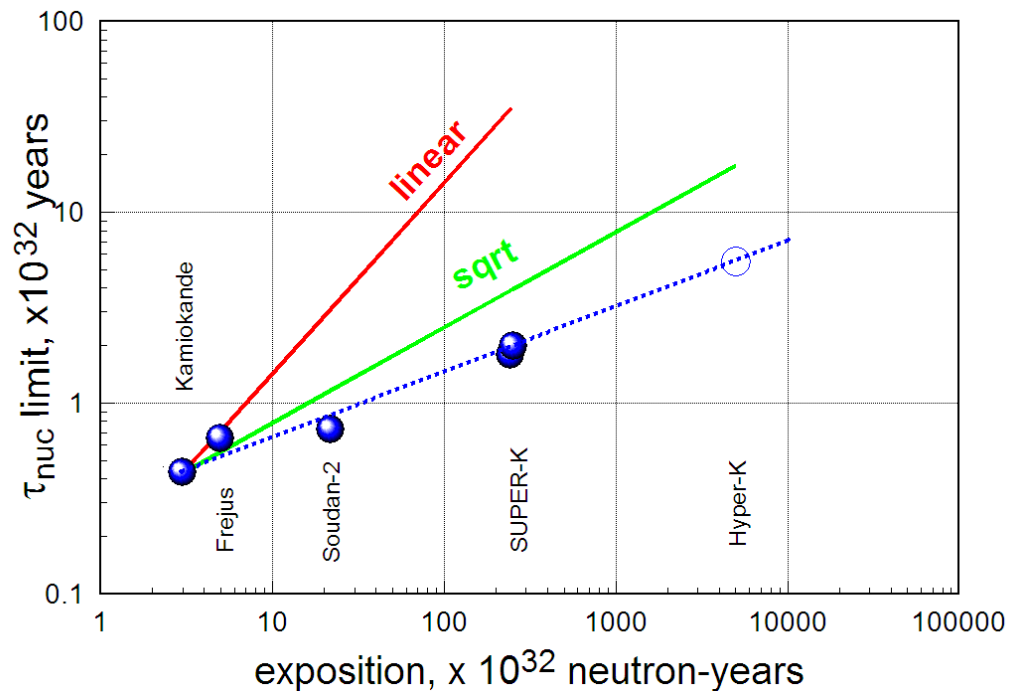

Observed improvement is weaker than SQRT due to irreducible background of atmospheric  $\nu$ 's.

Still possible to improve a limit (though slowly) but impossible to claim a discovery.

# N-Nbar transformation search with bound neutrons:

Best result so far from Super-K in Oxygen-16

$$\tau_{^{16}\text{O}} > 1.89 \times 10^{32} \text{ yr} \quad (90\% \text{ CL})$$

← { 24 observed candidates;  
24.1 exp. background

$$\tau_{\text{nucl}} = R \times \tau_{n\bar{n} \text{ free}}^2$$

if  $R_{^{16}\text{O}} = 5 \cdot 10^{22} \text{ s}^{-1}$  from Friedman and Gal (2008)

$$\Rightarrow \tau(\text{from bound}) > 3.5 \times 10^8 \text{ s} \quad \text{or} \quad \alpha < 2 \times 10^{-24} \text{ eV}$$

×16 times higher than  
sensitivity of ILL expt.



$$\tau_{nucl} = R \times \tau_{n\bar{n}}^2$$

# Free Neutron and Intranuclear NNbar Limits Comparison

Large improvement with free-neutron experiments is possible

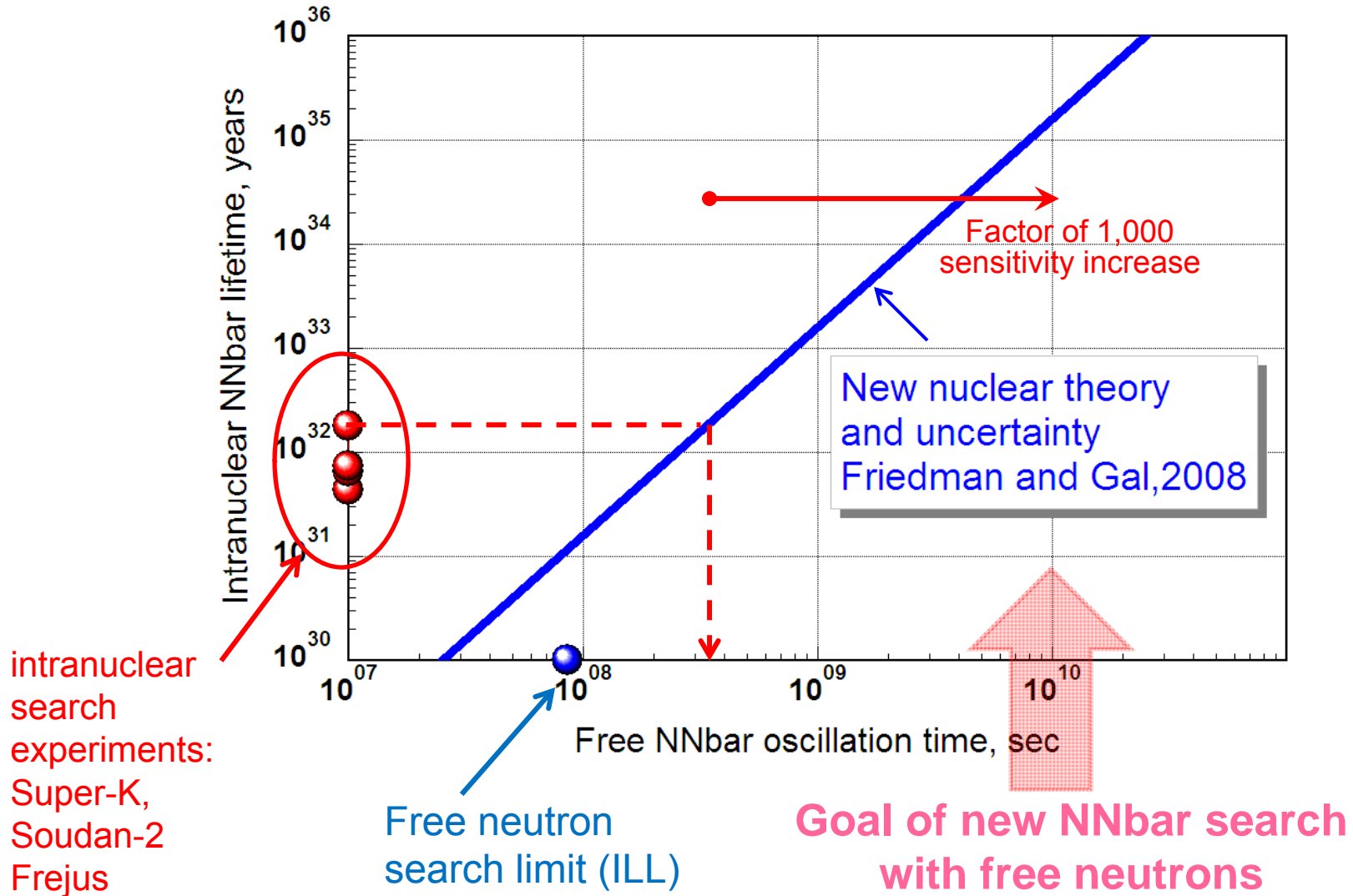

# Theoretical nuclear NNbar suppression model is incomplete

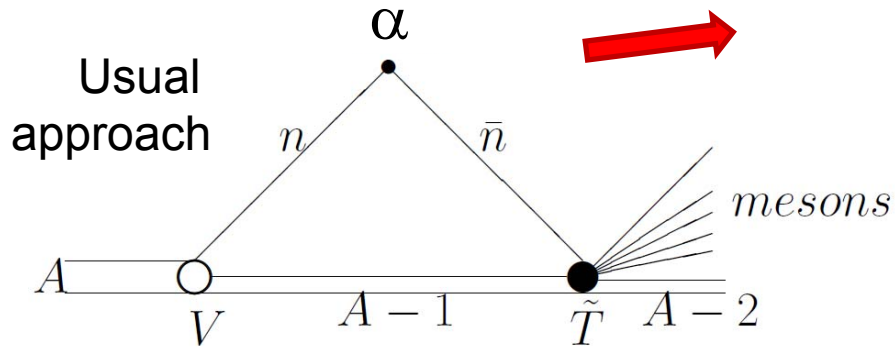

All these processes  $\rightarrow$   
 include the same amplitude  $\alpha$   
 and result in the same  
 indistinguishable final state  
 (of  $\sim 5 \pi$ s)

Existing intranuclear NNbar limits need to be re-evaluated

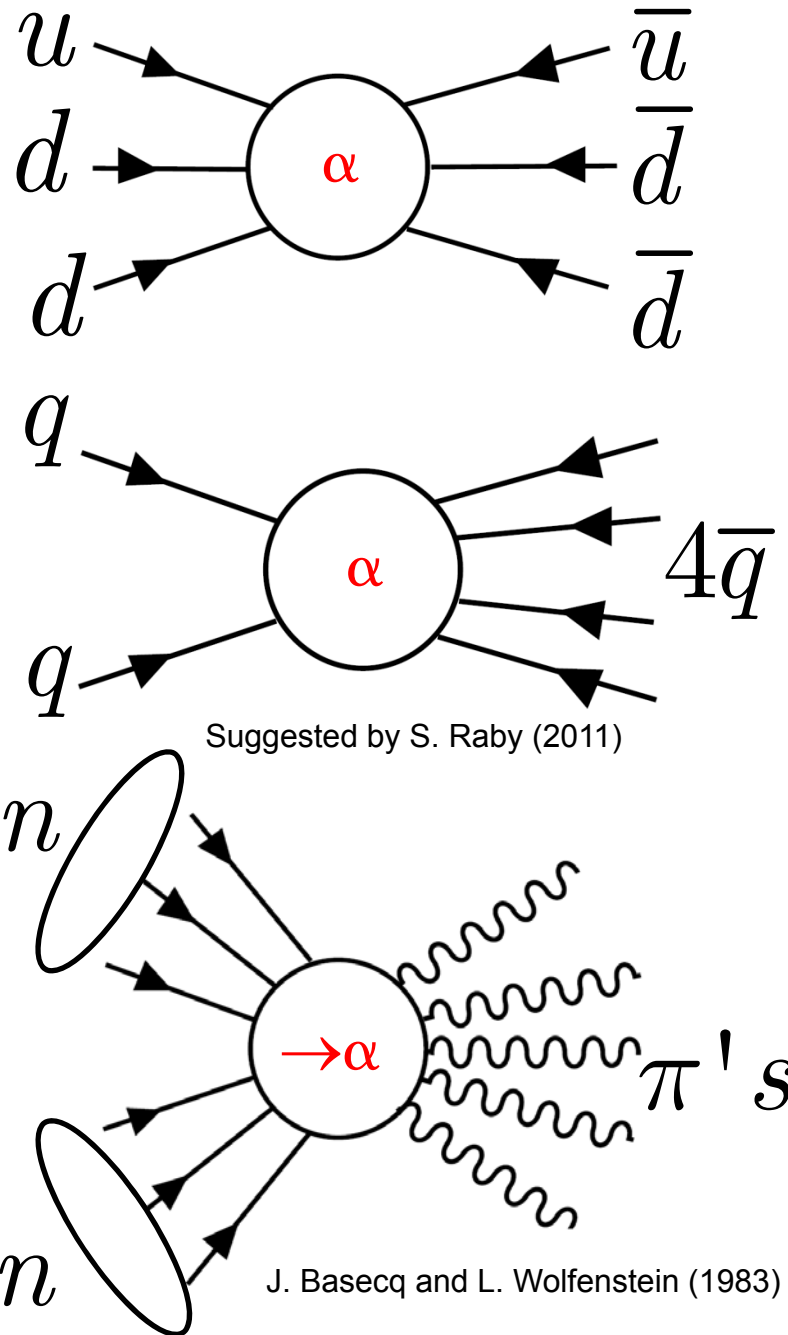

Suggested by S. Raby (2011)

J. Basecq and L. Wolfenstein (1983)

# Sensitivity improvement factors for $N \cdot t^2$

- Use many neutrons (spallation source or reactor)
- Use slow neutrons: cold, VCN, UCN
- Neutron manipulation by mirror reflections
- Neutron manipulation by gravity

# New $NN\bar{b}$ Search Proposed for Fermilab

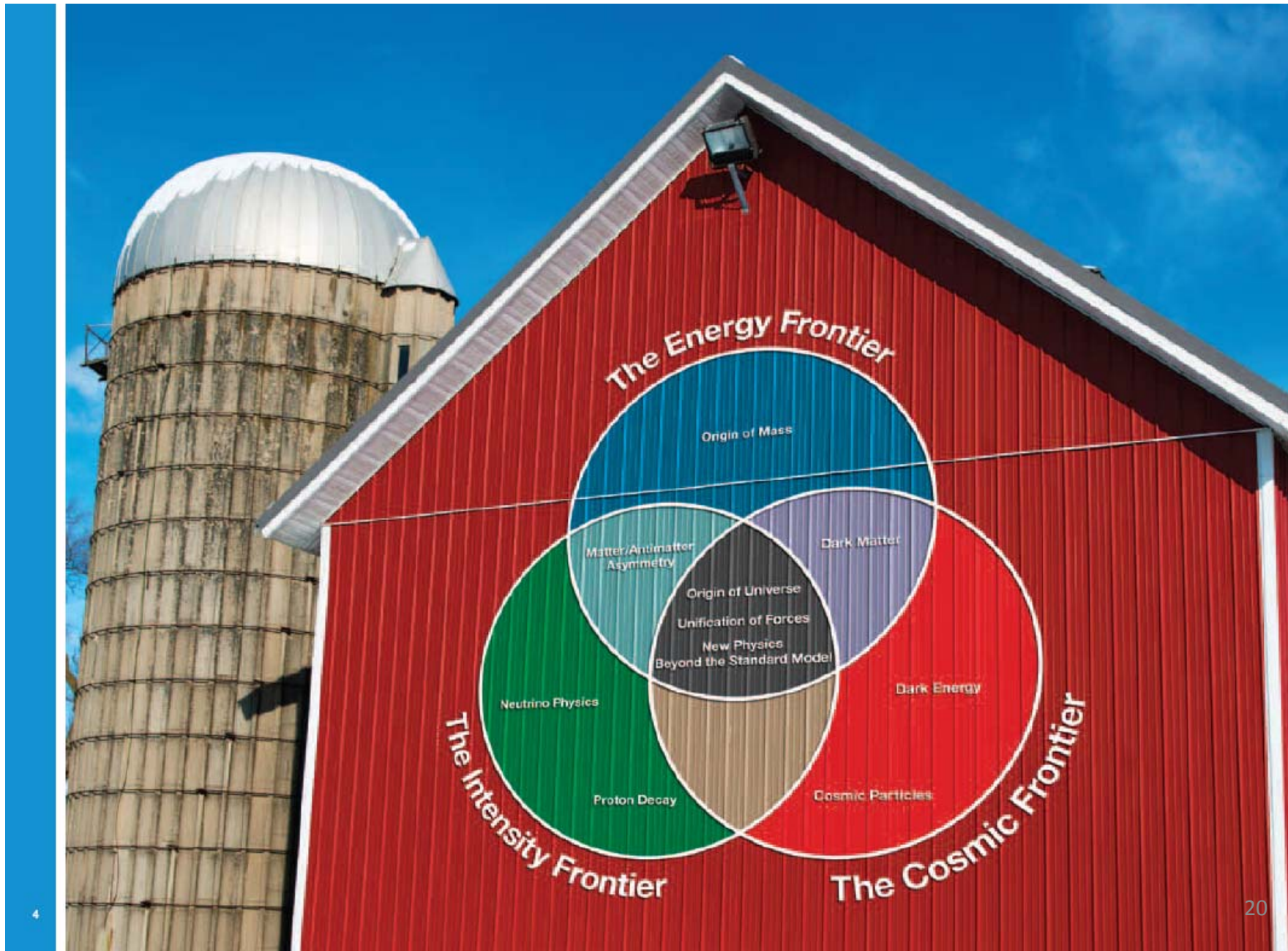



# Expansion of the Fermilab Accelerator Complex

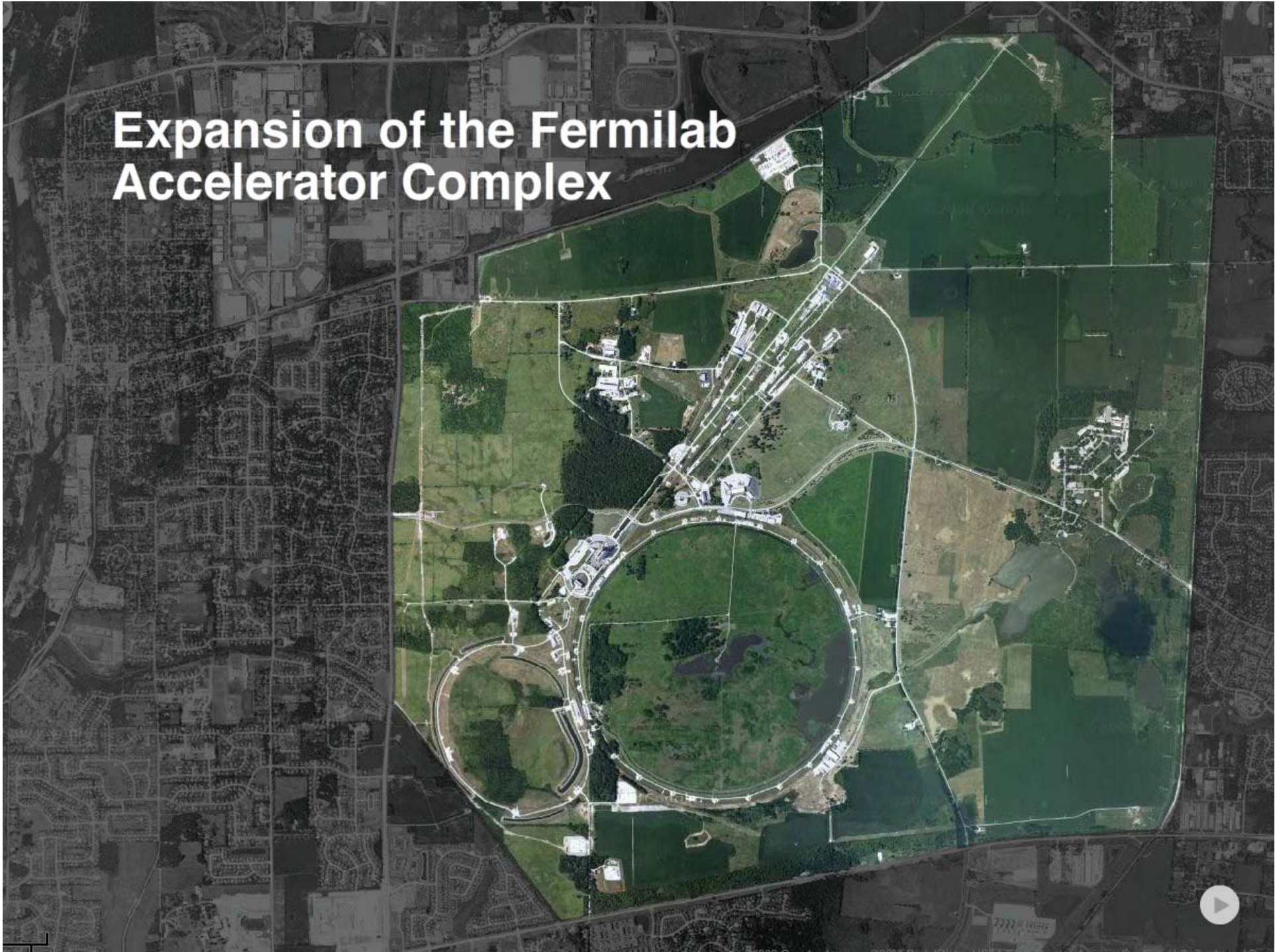



www.intensityfrontier.org

## Fundamental Physics at the Intensity Frontier

November 30 - December 2, 2011  
Rockville, MD

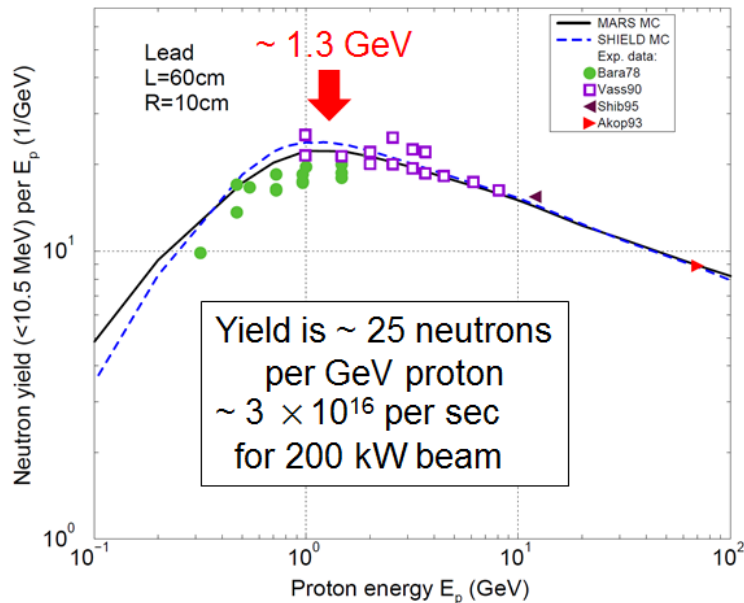
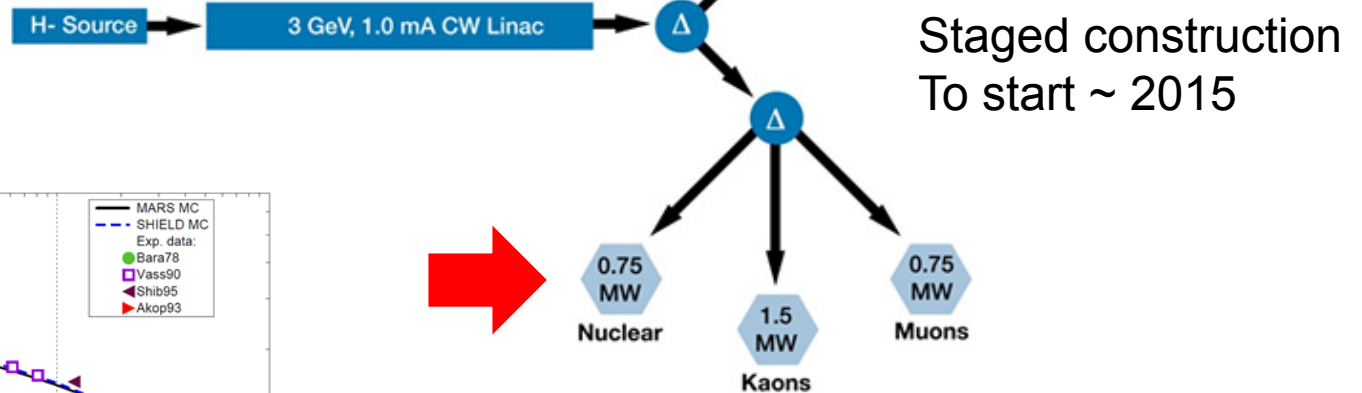

N. Mokhov, FNAL, 2011

# N-spallation target in Project X

## HEP Intensity Frontier



# Neutron reflection

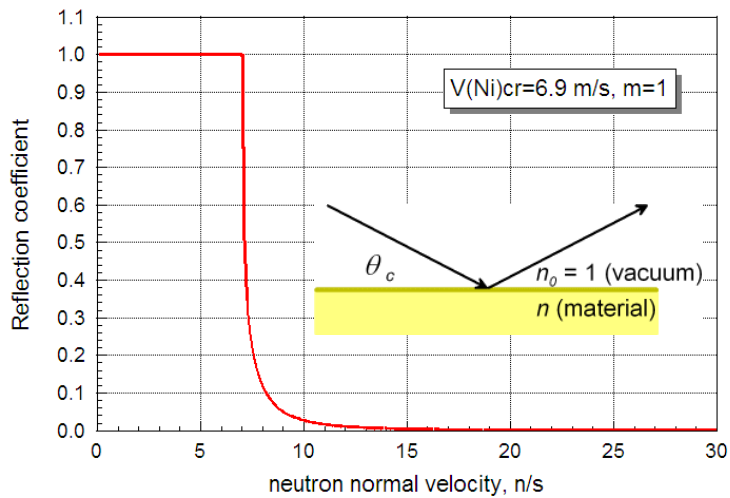
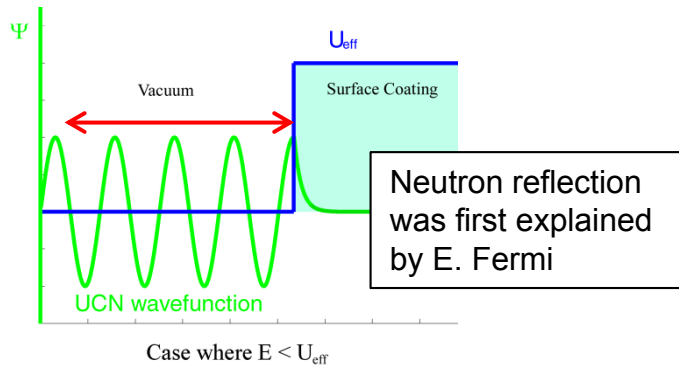

# Progress in neutron super-mirrors

H. Shimizu, KEK/Japan

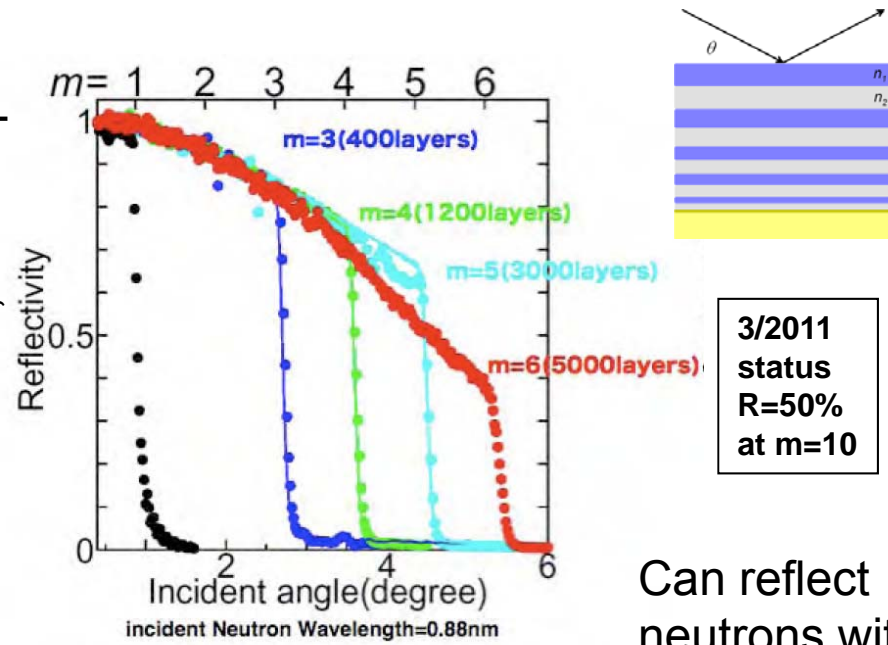

M.Hino et al., Nucl. Instrum. Methods A529 (2004) 54

# Generic View Of Cold Spallation Target

- Should try to use neutrons produced within  $4\pi$  rather than few % of  $4\pi$  for most n-beam lines

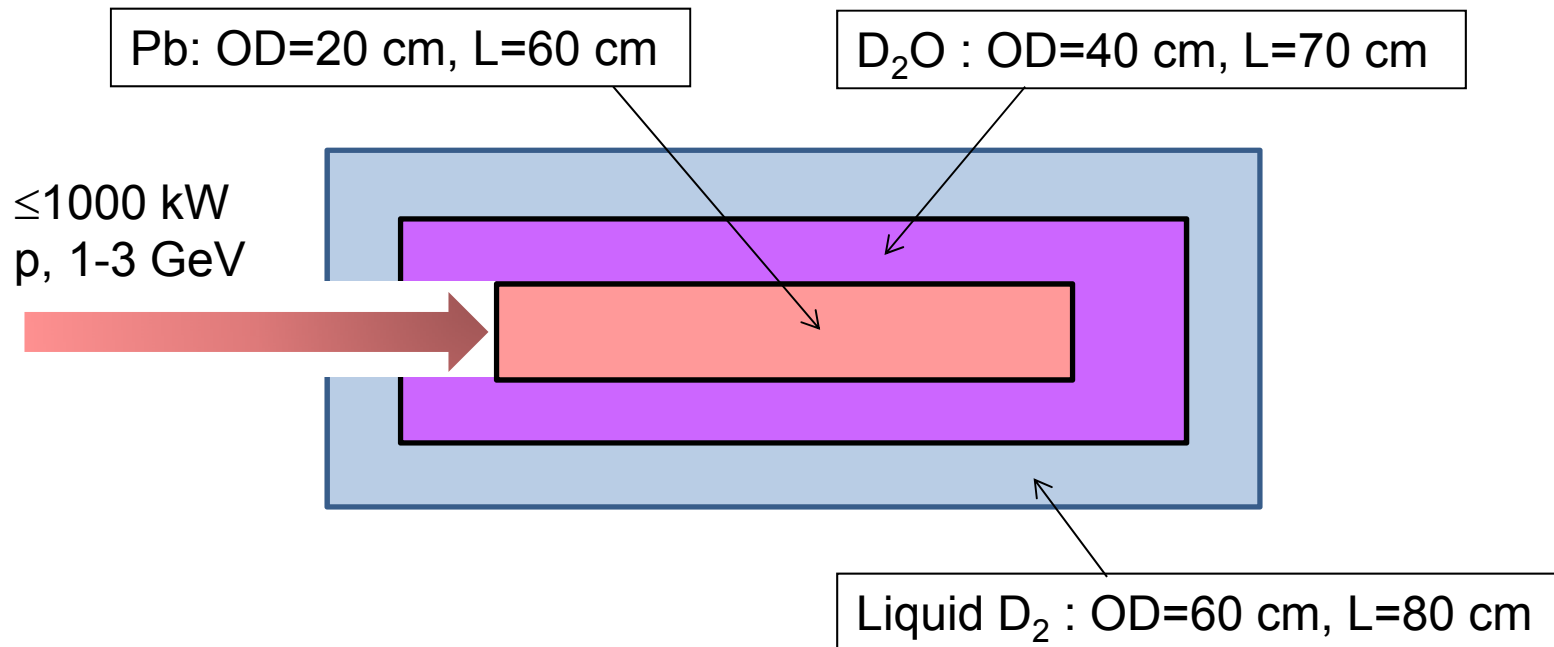

Spallation neutrons produced with kinetic energy  $\sim 2$  MeV should be moderated down to thermal  $T \sim 300$  K velocities  $\sim 2$  km/s and then to the cryogenic velocities  $\sim 600$  m/s. Some fraction of Maxwellian spectrum will have velocities  $\lesssim 100$  m/s



# Dedicated spallation target with VCN-UCN converter

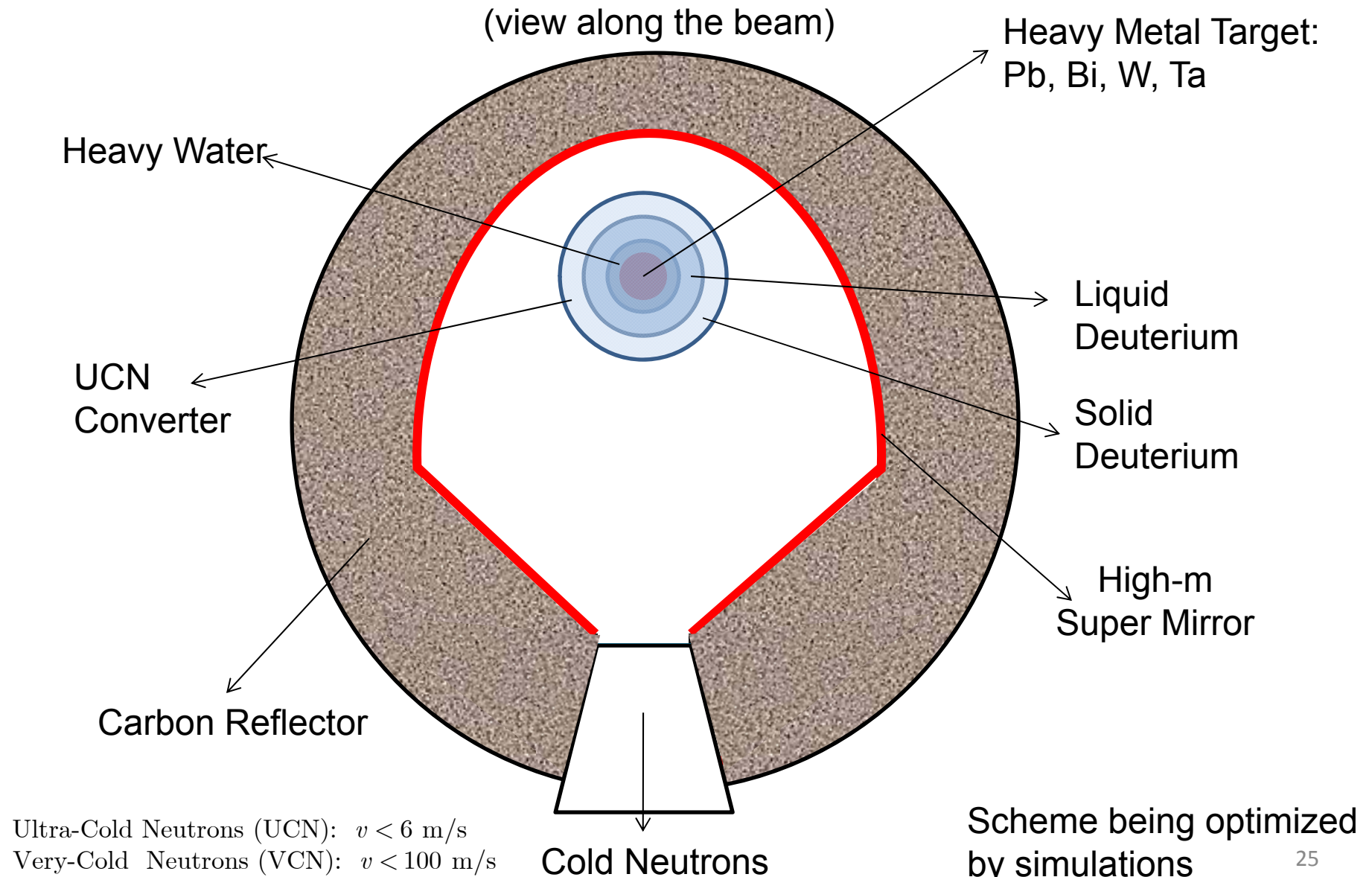

# NNbar search with spallation source at Fermilab with cold free neutron

E.g. using existing MINOS vertical shaft for housing the experiment.

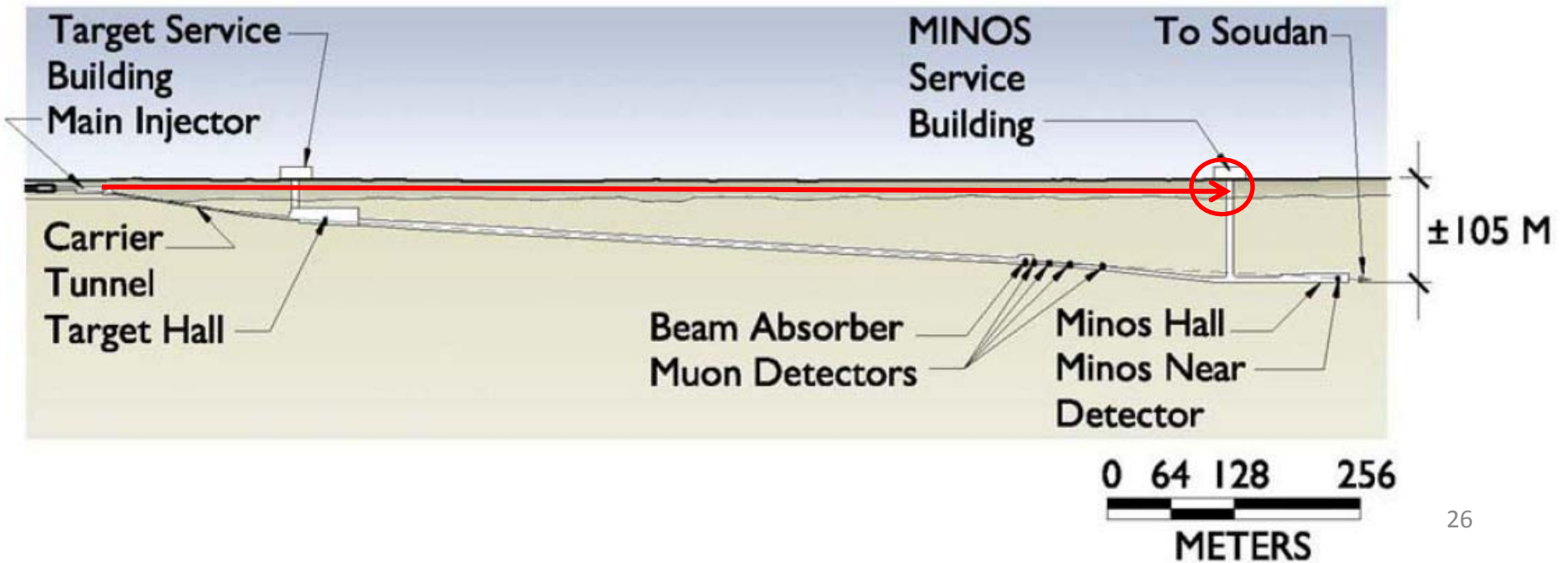
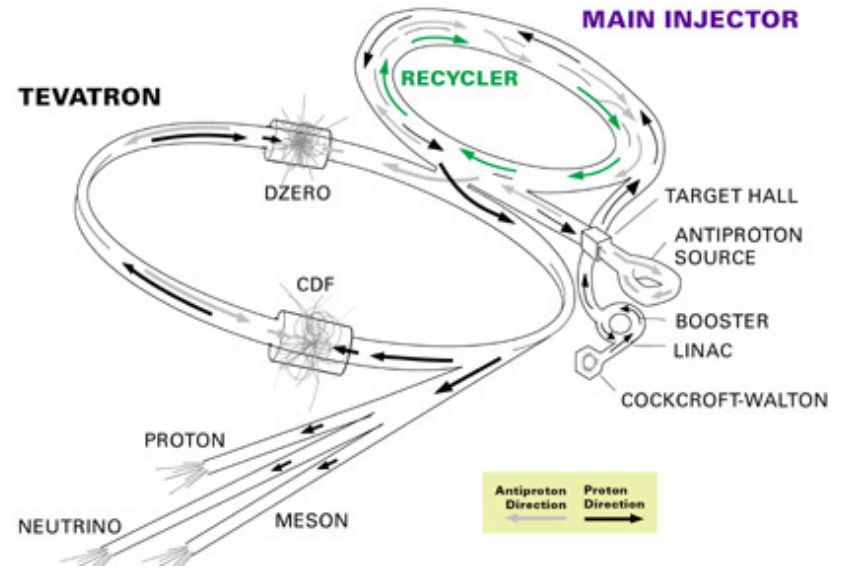

# New N-Nbar vertical scheme

- New concept of large focusing neutron reflector using super-mirror. Sensitivity increases as  $\sim L^2$
- Proton beam from MI or Project X; with power  $> 200$  kW
- Dedicated spallation target optimized for cold neutron production
- “Background free” detector: one event = discovery !
- Expected sensitivity  $> 2,000$  ILL units

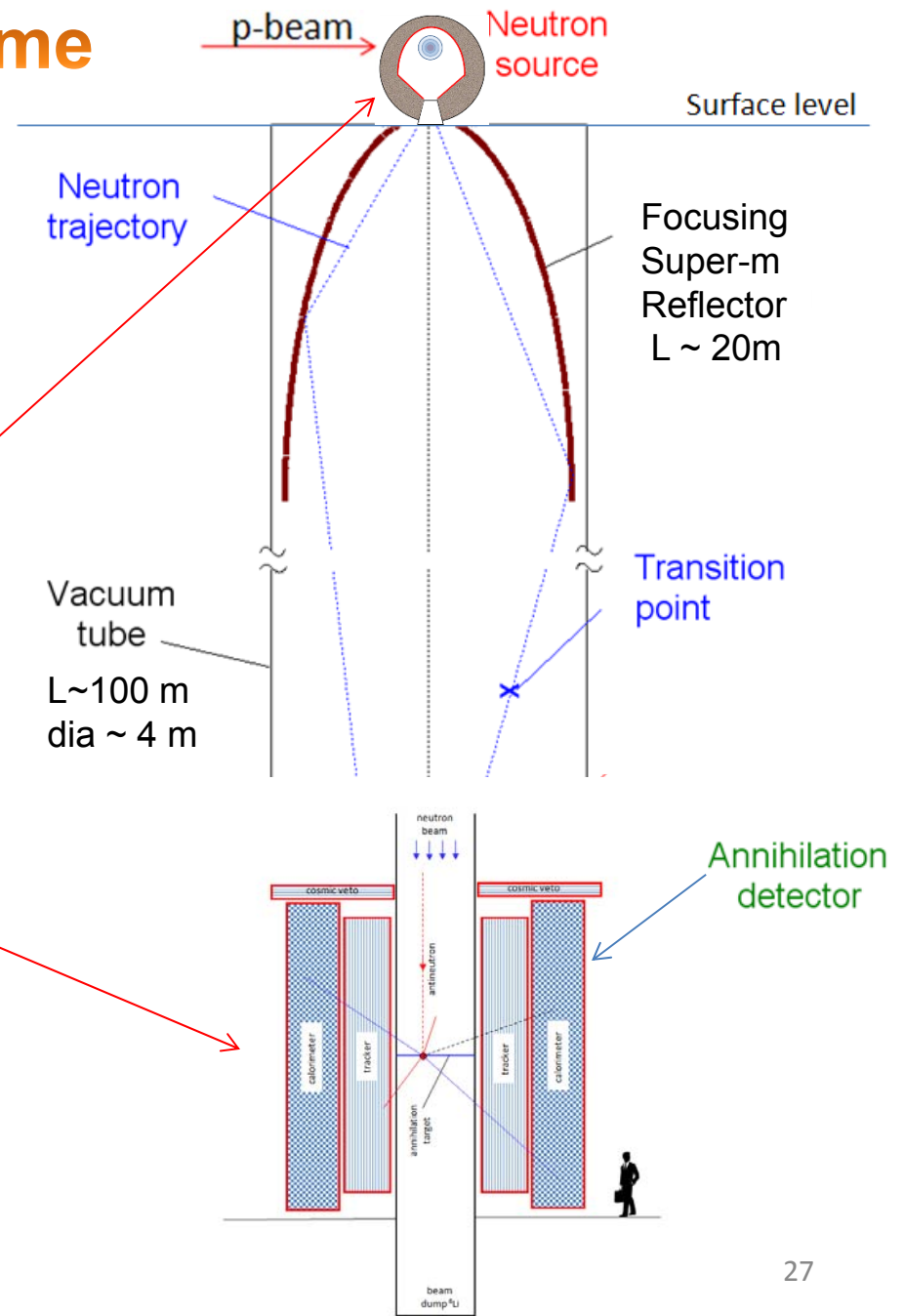

The conceptual scheme of antineutron detector for NNbarX experiment planned at Fermilab

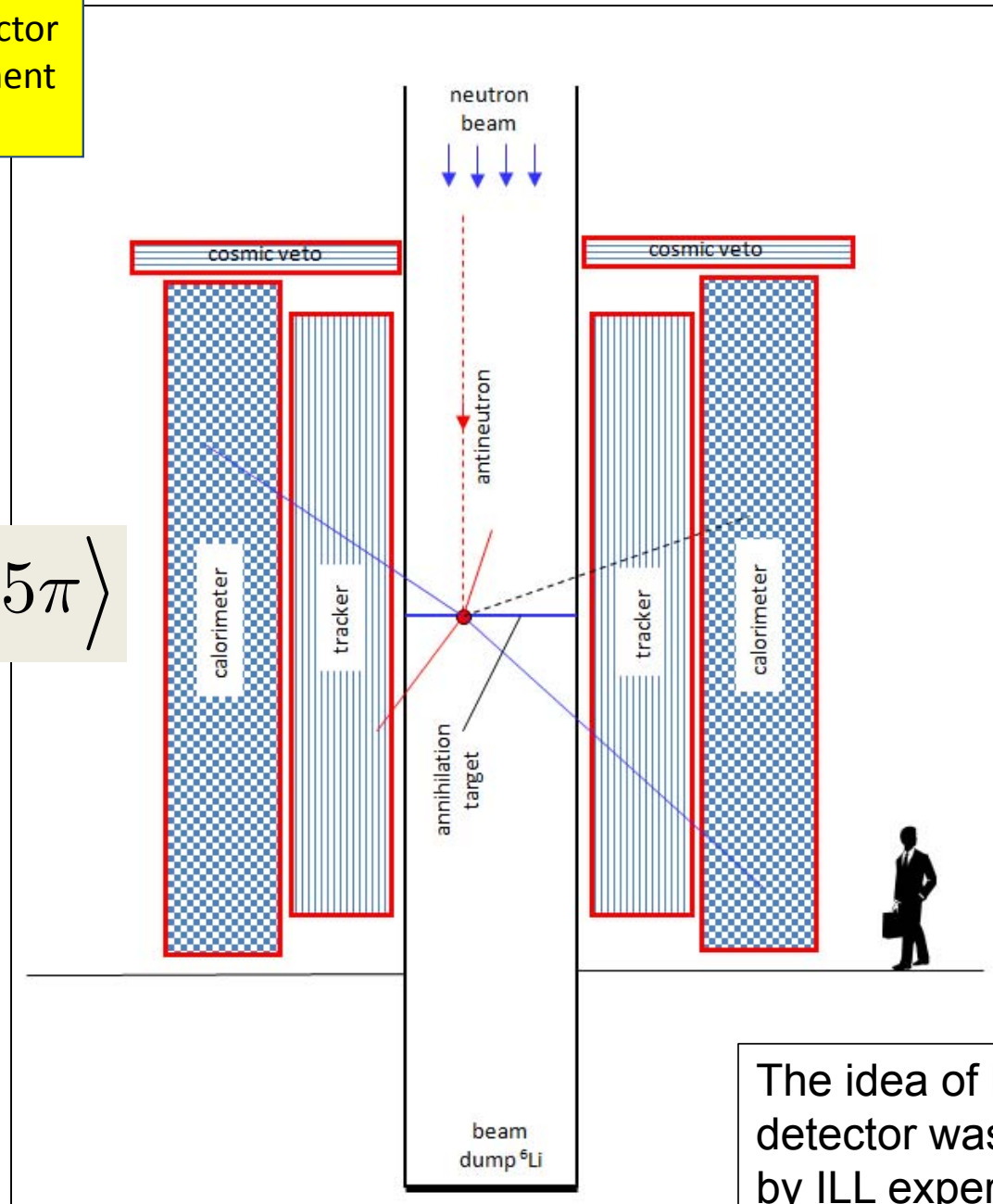
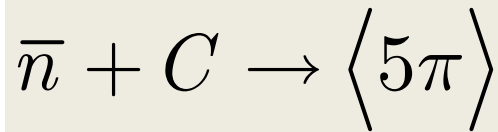

The idea of backgroundless detector was demonstrated by ILL experiment

# Vertical N-Nbar Experiment

*can be unique for  $n \rightarrow n'$  disappearance search  
if indications of ILL-based experiment will be confirmed*

<http://arxiv.org/abs/1203.1035>

Magnetic anomaly in UCN trapping: signal for neutron oscillations to parallel world?

Z. Berezhiani<sup>1,2</sup> and F. Nesti<sup>1</sup>

<sup>1</sup>*Dipartimento di Fisica, Università dell'Aquila, Via Vetoio, 67100 Coppito, L'Aquila, Italy*

<sup>2</sup>*INFN, Laboratori Nazionali Gran Sasso, 67100 Assergi, L'Aquila, Italy*

(Dated: March 7, 2012)

Present experiments do not exclude that the neutron transforms into some invisible degenerate twin, so called mirror neutron, with an appreciable probability. These transitions are actively studied by monitoring neutron losses in ultra-cold neutron traps, where they can be revealed by their magnetic field dependence. In this work we reanalyze the experimental data acquired by the group of A.P. Serebrov at Institute Laue-Langevin, and find a dependence at more than  $5\sigma$  away from the null hypothesis. This anomaly can be interpreted as oscillation to mirror neutrons with a timescale of few seconds, in the presence of a mirror magnetic field  $B' \sim 0.1$  G at the Earth. If confirmed by future experiments, this will have a number of deepest consequences in particle physics and astrophysics.



# PNPI Experiment to search for $n \rightarrow n'$ disappearance at ILL/Grenoble reactor, A. Serebrov et al (2009)

NIM A611 (2009) 137-140

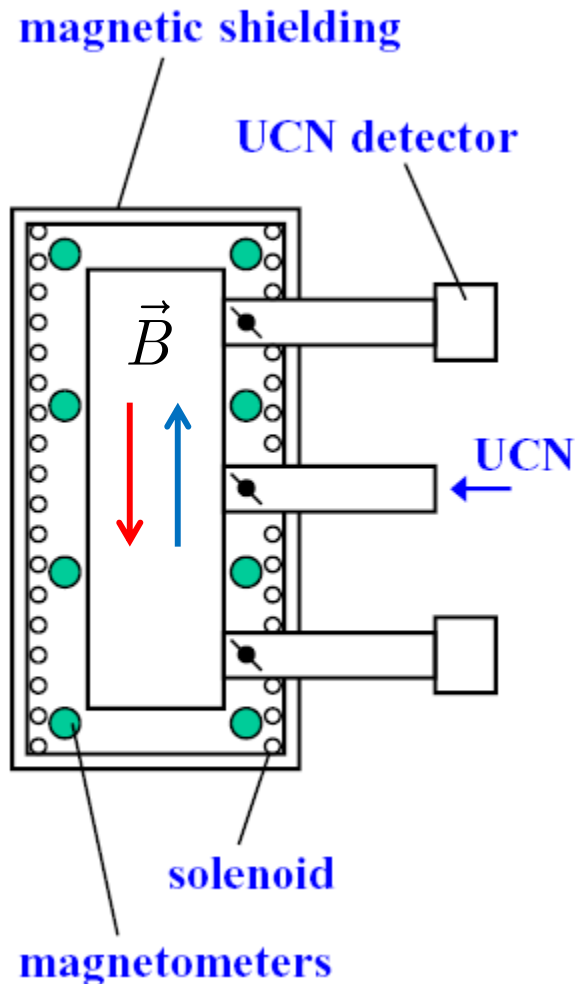

Measurements of UCN life-time asymmetry under alternation of vertical magnetic field

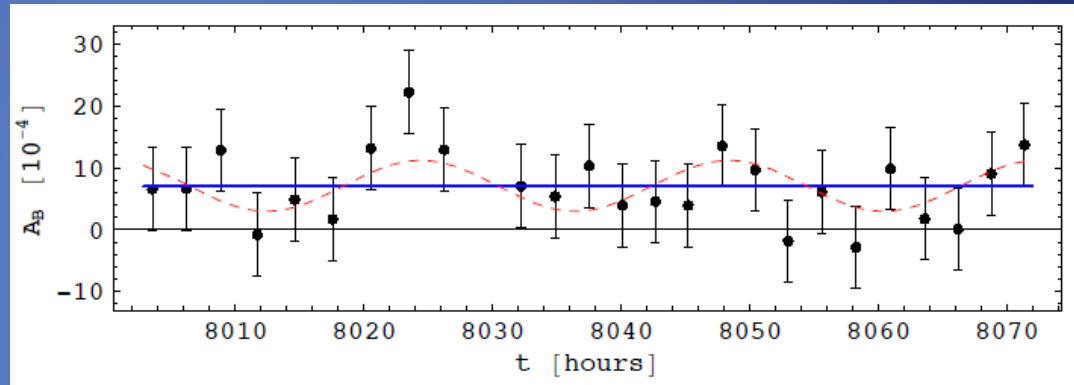

$$A_B^{\text{det}}(t) = \frac{N_{-B}(t) - N_B(t)}{N_{-B}(t) + N_B(t)}$$

Measured asymmetry  $\rightarrow$   
 $\sim (7 \pm 1.4) \times 10^{-4}$  ( $\sim 5\sigma$ )  
 $n \rightarrow n'$  oscillation time  $\sim 2-5$  sec;  
resonance mag. field  $\sim 0.1$  G

# Possible future $n$ disappearance with spallation source

- Let's assume that ~ 175 m long vertical shaft can be used
- 10 m/s neutron falls 175 m for ~ 5 s.
- Pulsed target operation would explore different velocities
- Controlled variation of lab field  $B$  and its direction should detect resonance in the disappearance
- If one absorbs all neutrons in the max of disappearance it will be possible to observe the regeneration effect (appearance on neutrons)

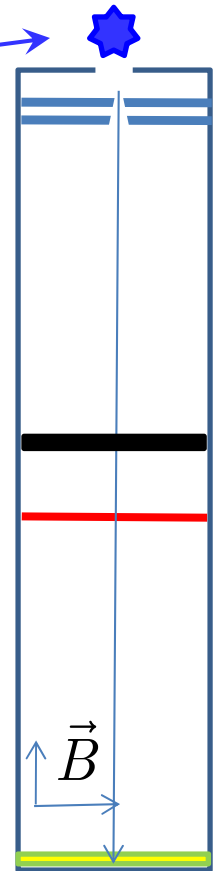

# NNbar Summary

---

New physics beyond the SM can be discovered by new NNbar search experiment

New direction within US Intensity Frontier initiative

Requires R&D on design of dedicated optimized spallation UCN-VCN source

Expected improvement in N-Nbar search sensitivity is a big factor of >1,000 that is within the predicted range of several models

Without a background one event can be a discovery !

Effect can be uniquely checked/controlled by weak magnetic field

## **If discovered:**

- $N \rightarrow N\bar{b}$  will establish a new force of nature and a new phenomenon of (B-L)V leading to the exploration of the new physics beyond the SM at the energy scale above TeV. Can be also an interesting CPT laboratory measuring  $\Delta m_{n-\bar{n}}$

## **If NOT discovered:**

- within the reach of improved experimental sensitivity will set a new limit on the stability of matter exceeding the sensitivity of XL nucleon decay experiments. Will test/constraint models of low scale baryogenesis.